

Chapter Comm 21
Subchapter I— Scope

21.02 (1) (a) Dead Load of Insulation

To avoid ceiling gypsum board sag or related problems, attic insulation dead load should not exceed gypsum board manufacturer's recommended capacity. This is especially true today where thick attic insulation and 24-inch truss spacing are common.

For example, one manufacturer, United States Gypsum, in its Gypsum Construction Handbook recommends that 3/8-inch gypsum board not be used to support insulation. They also specify that their other panel thickness may support insulation given the following load and framing spacing (gypsum board span) criteria:

<u>Maximum Load</u>	<u>Panel Thickness</u>	<u>Framing Spacing</u>
1.3 psf	1/2 inch	24 inch o.c.
2.2 psf	1/2 inch	16 inch o.c.
2.2 psf	5/8 inch	24 inch o.c.

Attic insulation materials vary in density and thermal properties. Therefore, the total weight per installed R-value will vary depending on type, installation method and manufacturer of insulation product. Some typical values are estimated below; check actual weights supplied from your manufacturer or installer.

<u>Type</u>	<u>Density</u>	<u>R/Thickness</u>	<u>R-38 Weight</u>	<u>R-50 Weight</u>
Cellulose	2.4 pcf	3.6/inch	2.1 psf	2.8 psf
Blown Mineral Wool	1.2 pcf	2.8/inch	1.4 psf	1.8 psf
Blown Fiberglass	0.6 pcf	2.7/inch	0.7 psf	1.0 psf
Loose Fill Fiberglass	1.1 pcf	2.5/inch	1.4 psf	1.8 psf
Fiberglas Batt R(19+19+13)	0.7 pcf	3.2/inch	0.7 psf	0.9 psf
Rigid (expanded polystyrene)	1.8 pcf	4.0/inch	1.4 psf	1.9 psf
Rigid (extruded polystyrene)	2.2 pcf	5.0/inch	1.4 psf	1.8 psf
Spray (polyurethane foam)	1.9 pcf	6.2/inch	1.0 psf	1.3 psf
Spray (open cell)	0.5 pcf	3.3/inch	0.4 psf	0.6 psf
Mineral fiber (rockwool)	2.0 pcf	2.3/inch	2.8 psf	3.6 psf

From the data above, most typical R-50 installations would exceed the capacity of 1/2-inch gypsum board on 24-inch o.c. framing unless the 1/2" gypsum board has been specifically designed for that purpose. However, 5/8-inch gypsum board on 24-inch framing (typical truss construction) would support most R-50 installations. Designers may want to check with the specific gypsum board manufacturer for span/load capacities when using 24-inch framing and high R-value cellulose installations. The above "USG" example indicates this may cause overloading.

21.02 (1) (b) 2. Live Load - Snow

Exterior balconies or decks should be designed to withstand 40 PSF as the critical live load.

21.02 (2)

The effect of drifting or sliding snow on a roof should be considered as a matter of good design practice. However, the UDC only requires a 30 or 40 PSF snow load applied uniformly to roofs. In complex roofs with side by side low-high portions or flat roofs below sloped upper roofs, a designer may want to consider potentially higher snow loads in the low roof areas where sliding or drifting snow may collect.

The UDC does not set lower snow live load values for roofs with glass or other slippery surfaces. Comm 21.27(1)(c) does allow a reduced snow load for steeper roofs with slopes of 7 in 12 or greater. Otherwise, attached greenhouses, solar spaces, solar panels and other similar roof construction should be designed to withstand 40 or 30 PSF for zone 1 or 2 respectively.

21.02 (1) (d) Fasteners

The fastener schedule in the appendix presents one means of showing adequate fastening to meet the code in most typical designs with sawn lumber. However, it may not be sufficient for certain designs, especially those using engineered lumber that can handle greater spans and loads than those assumed in the appendix fastener table. Be sure to verify that the fasteners provided will adequately transfer the greater loads that required special lumber.

21.02 (1) (d) Dwelling Anchorage

Question: When does a dwelling need to be anchored to the foundation?

Answer: This section only discusses anchorage of the aboveground portion to the foundation. This is to prevent potential movement of the upper level due to wind pressure.

Section 21.18 requires the top of the foundation wall to have adequate lateral bracing to the floor above to resist lateral soil loads, as through anchor bolts or other means. Where failures of foundation walls have occurred in the past, investigation has shown that many times damage could be attributed to lack of lateral support at the top of the walls rather than to faulty material or workmanship. In other cases, the use of a weak mortar in the masonry walls was an important contributing factor. The practice of some contractors backfilling basement walls before the first floor lateral support system is in place contribute to failures.

In order for the floor system to provide lateral support where the joists are parallel to the foundation wall, solid bridging or blocking needs to be installed between the rim joist and adjacent floor joist.

21.02 (2) "Typical" Structural Analysis

Question: A builder submits a building plan and includes "typical" structural calculations. Is there any time limit placed on the acceptability of such calculations?

Answer: Usually the typical calculations correspond to a master plan of a home built repetitively. When reviewing the building plans, you should verify that the loading conditions, spans, member sizes, member spacing and lumber grade as specified in the "typical" calculations are consistent with the plans. The use of such typical calculations or span tables (as in the Appendix to Ch. 21) is generally acceptable as long as the design criteria coincide with the building

plans. There would be no time limit on the use of such calculations as long as they do not conflict with the requirements of the current code. An update of the calculations should be required if the code changes and different loads, load duration factors or other design criteria become effective.

21.02 (2) Manufacturer's Installation Requirements

Section Comm 21.02(2), requires that all dwellings be designed by the method of structural analysis or the method of accepted practice. It is accepted practice to install a material in a manner required by the material's manufacturer, if the installation is regulated by the code. A material installed in a manner that is inconsistent with the manufacturer's requirements should not be allowed unless additional information is provided showing that the installation will still meet the performance requirement of the code. An example is listed equipment--if the equipment is not installed per manufacturer requirements, the acceptance provided by the listing is not applicable. A manufacturer's installation requirement must also be checked for compliance with the Uniform Dwelling Code. It is the responsibility of the builder to have manufacturer's installation instructions available for review by the inspector (per s. Comm 20.09) when a question of proper installation arises.

21.02 Engineering Terms Used in the Code or Referenced Standards

1. ALLOWABLE STRESS (F)

- Determined by physical testing of wood specimens of different grades and species.
- Tabulated value already has a built in factor of safety.
- Historically done by visual inspection of wood for defects (knots, checks.....) = Visual Graded.
- Also can be done by machine by testing deflection-vs-load = Machine Stress Rated (MSR).

2. LATERAL SUPPORT

- Structural bracing or interconnection that prevents movement of a structural member in a specific direction, usually perpendicular to the direction that the main structural member is providing support.
- Examples:
 - bridging to joists
 - corner bracing to studs (let-in 1 x 4, metal straps, plywood panels)
 - subfloor to joists
 - sheathing to trusses
 - floor system to foundation walls
 - basement floors to foundation walls

3. MODULUS OF ELASTICITY (E)

- Ratio of stress/strain.
- For a given force applied to a material, you can predict the deformation if you know E.

4. BENDING MOMENT (M)

- Force x distance (inch-lbs).
- Causes curvature deformation in beams or columns.
- Causes tension and compression stresses in beams and sometimes columns.

21.02 (3) (b)

5. MOMENT OF INERTIA (I)

- Used in the calculation of beam deflection.
- Geometric property of a structural member.
- $I = \frac{bd^3}{12}$, inches⁴ (rectangular beam), b = width, d = depth

6. SECTION MODULUS (S)

- Geometric property of a structural component (beam, column . . .).
- $S = M/F_b$, inches³
- $S = \frac{bd^2}{6}$ (rectangular beam), b = width, d = depth

7. STRAIN

- Deformation, (stretching, compaction, curvature) caused by an external force.

8. STRESS* - Internal resistance to an external force.

- Generally in lbs/in² (psi).

- F_b = bending stress;

Resists curvature due to bending moment (Force).

- F_c, F_t = axial compression or tension stress;

Resists perpendicular compaction or stretching due to a longitudinal force.

- F_v = shear stress;

Resists slippage in plane of the surface parallel to the end face of the beam.

*Capitol (F) denotes "allowable" stresses in a material samples as determined by testing and adjusted by factors permitted by the applicable material standard. Small case (f) denotes "actual" calculated stress of a structural member as based on design loads.

21.02 (3) (b) Structural Analysis Standards - Wood

The following code-referenced standards shall be used in the design of roof and floor trusses.

The 2005 edition of the "NATIONAL DESIGN SPECIFICATIONS FOR WOOD CONSTRUCTION" and its supplement, "DESIGN VALUES FOR WOOD CONSTRUCTION," as published by the American Forest & Paper Association.

The "DESIGN SPECIFICATIONS FOR METAL PLATE CONNECTED WOOD TRUSSES" TPI-02 as published by the Truss Plate Institute, Inc.

The department has determined that the design minimum live load in Table 21.02 for ceilings with storage of 20 PSF applies to stick-built frame construction. Roof trusses designed in accordance with TPI-02 for attic storage loading will meet the intent of the code, only if such design criteria has been identified on the truss and drawings.

21.02 (3) (b) Outline of the National Design Specification (NDS)

This specification is adopted by the UDC s. Comm 20.24(2)(a) and s. Comm 21.02(3)(b). The NDS is used for structural design of wood members as an alternative or in addition to the prescriptive (accepted practice or "cookbook") standards in Ch. 21. It is the basis for the development of the Fastener and Span Tables in Appendix App-17 of the UDC. Its accompanying NDS Supplement provides allowable stress values depending on grade, species and dimensions of lumber used. It is also the basis for "Design Values For Joist And Rafters-Visual Grading" tables in Appendix App-17.

NDS Part I General Requirements for Structural Design

- Includes guidelines for use of NDS considering the effects of:
 - Bracing
 - Connections at joints
 - Adequate load assumptions
 - Most conservative load combinations
- The NDS is intended to be adopted by governing codes such as the UDC which may prescribe the above minimum load and load combinations.

NDS Part II Design Values

- Allows for modification of design stresses due to:
 - Moisture conditions
 - Temperature
 - Preservative treatment
 - Fire retardant treatment
 - Duration of load.

Not all stress modifications are necessarily applicable to all beam and column installations.

Introduces the concept of a Load Duration Factor (LDF). The LDF will adjust allowable stresses, generally upward, to recognize that wood is more responsive in resisting short term loadings.

- Floor Live Load = 1.0 (10 years)
- Snow Load = 1.15 (2 months)
- Roof Live Load = 1.25 (7 day)
- Earthquake, Wind = 1.6 (10 minutes)
- Impact = 2.00 (2 sec)

NDS Part III General Design Provisions and Formulas

1. Beam Design

- Formulas listed in text (also see s. 21.22(3) of this commentary).
- Notching of beams - limitations similar to UDC.
- In general, the NDS assumes rectangular sections (sawn lumber) are used. Certain modification factors can be used for other shaped (round) members. Also, other shaped members will have different geometric properties that will alter the "typical" formulas referenced in this commentary.

21.02 (3) (b)

- Beam formulas can be complicated by and thereby adjusted to compensate for:
 - lack of lateral support
 - relatively long beam length
 - beam shape: round, rectangle, diamond
 - Beam design must also consider:
 - Shear stress (f_v), especially for heavily loaded members.
 - Deflection considerations, especially for long spans or when the joist/beam depth is relatively small.
2. Column Design, Axial Compression (C)
- Formulas listed in NDS.
 - Compression members can be horizontal or vertical (trusses).
 - Column design is a function of:
 - Area
 - Compressive Stress, f_c
 - Column length, l
 - Column width, d
 - Shape: round, square, tapered
 - There is no one simple formula because of the many interrelated factors listed above.
3. Tension Members, Axial Tension (T)
- Formulas listed in NDS.
 - Member design is a function of:
 - Area
 - Tensile stress, f_t
 - Usually end connections are most critical in design.
4. Combined Axial (T or C) & Bending Stress
- Common in truss design and pole buildings.

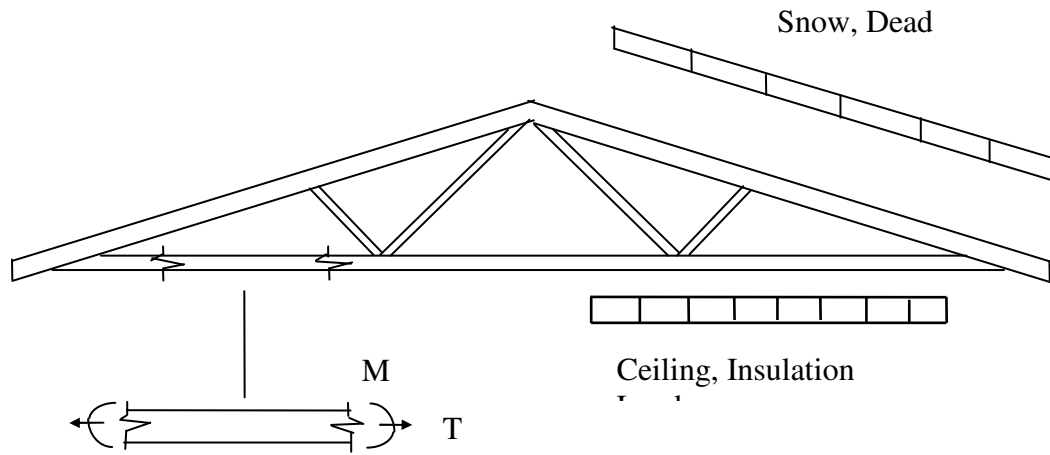

Member
Stresses: Axial Tension and
Bending Moment

- Formulas listed
- Simplest case:

$$f_b/F_b + f_{t(c)}/F_{t(c)} \text{ less than or equal to } 1.0$$

f = actual member stress
 F = allowable member stress

- This means that the sum of the percentage of actual bending tension (or compression) stress plus the percentage of actual axial tension (or compression) stress should be less than 100 percent of allowable tension (or compression) stress. That is, allowable stress equals the sum of the contributions from bending plus axial allowable stresses.

NDS Part IV Sawn Lumber

- Refers to design values given in NDS Supplement. Allowable stresses differ depending on single-vs-repetitive member use.
- Single member use
 - individual member responsible for carrying entire load
 - example: beam, column
 - no "near neighbors" to share load
- Repetitive member use
 - bending members only
 - spaced 24 inch on center or less
 - not less than 3 in number
 - joined by floor or roof decking to spread load to adjoining members

21.02 (3) (b)

- example: joists, rafters, trusses, built up beams, wall studs

NDS Part V Structural Glued Laminated Timber

(Also see further information in this commentary section.)

- General Design Values based on visual and machine stress rated methods given in Tables 5A, 5B, 5C and 5D of the NDS Supplement.
- Design values can be modified due to service condition, etc., similar to those specified in Part II.
- Curved glued laminated members (arches) are possible and special consideration is specified.
- Glued laminated members subject to compression or combined tension-compression are designed per Part III with some additional requirements.

NDS Part VI Round Timber Piles

- Rarely used for UDC construction.
- Specifies types of preservative treatment, typical dimensional requirements per American Wood Preservers Association (AWPA) and ASTM standards.
- Design values and modification factors based on service condition, size and condition of preservative treatment.

NDS Part VII Prefabricated Wood I-joists

- New section for NDS 2001 and often used in UDC construction.
- Load duration factor is applicable, as well as beam stability factor
- Repetitive member factor $C_r = 1.0$

NDS Part VIII Structural Composite Lumber

- New section for NDS 2001 and often used in UDC construction.
- Load duration factor is applicable, as well as beam stability factor
- Repetitive member factor $C_r = 1.04$ for 3 or more joined within 24"

NDS Part IX Wood Structural Panels

- New section for NDS 2001 and often used in UDC construction.
- Load duration factor is applicable
- References American Panel Association (APA) documents for plywood, oriented strand board (OSB) and composite panels for design and construction recommendations of structural assemblies consisting of panel products.

NDS Parts X & XI Mechanical Connections & Dowel-type Fasteners

- Tables give design values, load per fastener, for:
 - nails (common, box, etc., with minimum diameters)
 - screws (lag, wood)
 - bolts
- Minimum penetration of a lag screw is four times its diameter
- Minimum penetration of a lag screw is four times its diameter
- Edge distances, end distances, and spacing of nails and spikes shall be sufficient to prevent splitting of the wood
- This information is used to develop the fastener table in UDC Appendix.

NDS Part XII Split Ring and Shear Plate Connectors

- Tables give design values, load per fastener, for:
 - split rings
 - metal plates

NDS Part XIV Shear Wall and Diaphragms

- New section for NDS 2001 and often used in UDC construction.

NDS Part XIII Timber Rivets, Part XV Special Loading Conditions, and Part XVI Fire Design of Wood Members

- New sections for NDS 2001 and not often used in UDC construction.

NDS Supplement: Design Values

- Depending upon species, grade, and size classification, design values are provided for various loading situations:

F_b - Allowable bending stress, psi

F_c - Allowable compressive stress (parallel to grain), psi

$F_{c\perp}$ - Allowable compressive stress (perpendicular to grain), psi

F_t - Allowable tension stress, psi

F_v - Allowable shear stress, psi

E - Modulus of Elasticity, psi

- Some values also reprinted were based on the 1991 NDS.

Note: See Appendix for complete tables for all species and values.

Overview Of Important Issues Regarding Trusses

1. Per s. Comm 21.02(3)(f) and Table 20.24-13

Trusses should conform to TPI 1-2002, "National Design Standard for Metal Plate Connected Wood Truss Construction."

2. Per s. Comm 20.09(5)(b) The designer may be required to submit plans showing the truss design is consistent with or shows:

- house framing plan
- bearing and connection/anchorage details
- design loads
 - top and bottom chord load

21.02 (3) (b)

- live, dead, wind load
- concentrated or nonuniform loads
- outside configuration of components
- permanent bracing system if required
- connector plate size per joint

3. Per s. Comm 20.09(6)(a)

The designer may be required to submit data including:

- stress calculations (axial, bending, &/or combined)
- species, grade, size of members
- member forces
- reactions
- connector plate capacity required per joint

Additional Background Information Glue Laminated Timber⁽¹⁾

1. Used for long spans, large loads and architectural effect.

1. Relatively thin laminations of wood combined to practically any length and size.

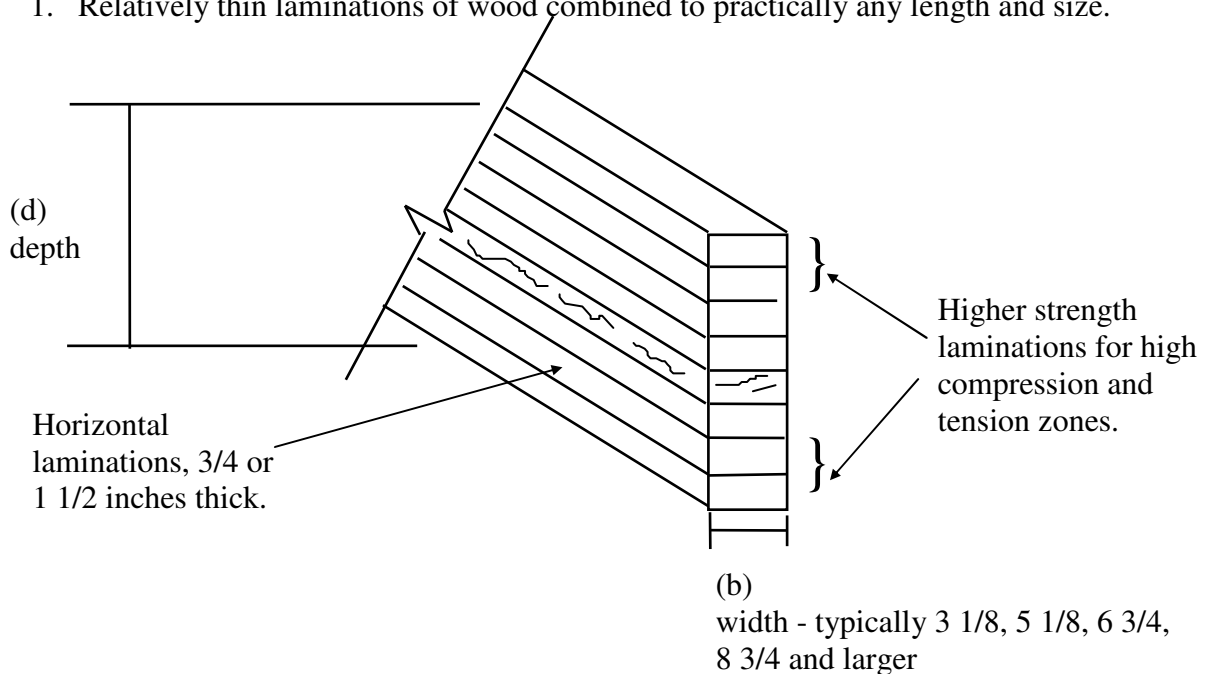

3. Relatively higher structural properties.

- Laminations of high quality wood
- Defects - Knots etc., spread out, not continuous for depth or width of member
- Maximum 2600 psi bending stress = F_b , compared to 1900 psi for sawn lumber

4. Glue generally for wet use applications with some dry use glue allowed, but not common.

5. Graded differently than sawn lumber.

- 24F indicates allowable bending stress = 2400 psi under normal conditions.
- V1, V2 etc., refers to Visual Graded No. 1 or 2.

- E1, E2 refers to Machine Grading by testing the Modulus of Elasticity.
6. Some condition of use and load duration adjustment factors may apply.
 7. Design properties are included in the NDS Supplement.

(1) Source: Breyer, Donald E., *Design of Wood Structures, Mc Graw Hill, 1980.*

21.02(3)(b)1.b. Re-Used Graded Lumber

Sound used lumber with grade marks still identifiable may be used for one- and two-family dwellings as follows:

The published NDS allowable design stresses for the lumber species and grade represent values for new lumber. To apply to used lumber, formerly these were to be reduced to a 90 percent value. NOTE: For joists and rafters, use "F_b" for repetitive-member use under normal duration load conditions. These used, 90 percent reduced bending values should not be increased using LDF's for snow or construction loading conditions. The span tables for joist and rafters in the appendix of the code may be used with the reduced design stresses.

Used re-sawn graded lumber must be graded based on the re-sawn and certified in accordance with nationally recognized lumber grading rules for visually graded lumber per ASTM D245. Agencies publishing grading rules are listed in the NDS "Design Values for Wood Construction."

Sound lumber is defined as materials without structural damage such as splits, cracks, gouges, saw, rot or insect damage and with notching and borings limited as follows:

21.02(3)(b)3. Native Sawn Ungraded Lumber

Sound, native, sawn un-graded lumber may be used for one- and two-family dwellings per the NDS published allowable design stresses for the lumber species using No. 3 grade when used for studs, stair stringers, rafters or joists and No. 1 grade for beams, posts or timbers in lieu of certified graded lumbers. How may this section be applied?

Example #1:

1. I have an Eastern White Pine ungraded 2 X 4.. Can I use it as stud material?
2. Default Grade 3 can be applied to this lumber. In accordance with the lumber species and grade table in the UDC code appendix, grade number 3 has an F_b of 605 psi.
3. This F_b value is greater than the stud grade for the same species (570 psi) required by Table 21.25-A. Therefore, it is OK to use this for a stud.

Example #2:

1. I have an Eastern White Pine ungraded 2 X 10. Can I use this as floor framing material?
2. Default Grade 3 can be applied to this lumber. In accordance with the lumber species and grade table found in the UDC code appendix, grade number 3 has an F_b of 445 psi and a modulus of elasticity of 900,000 psi.

21.02 (3) (b)

3. To determine the maximum permitted span for this lumber to be used as a floor joist, go to UDC code appendix Table F-2.
4. The maximum span for a 2 X 10 with a modulus of elasticity of 900,000 psi spaced at 12" on center is 14'-11".
5. Note, though, that the table minimum F_b for this member spaced at 12" o.c. is 777 psi. This default Grade 3 lumber in question has an F_b of 445 psi. Therefore, this lumber may not be used without structural analysis.

2007 Wisconsin Act 208 became law on April 22, 2008. This law permits individuals that saw their own lumber on site to "self-grade" their lumber. The person that does the self-grading must take a basic lumber grading program developed by the forest products outreach program at the UW-Stevens Point. Go to the website <http://www.legis.state.wi.us/2007/data/acts/07Act208.pdf> to get more information on this act.

An alternative for lumber species not listed in the NDS "Design Values for Wood Construction" and where nationally recognized allowable design stresses are not available, structural testing of the materials will be required. Testing must be conducted by a recognized independent testing agency in accordance with the appropriate ASTM load test procedure. The cost of such testing shall be borne by the person applying for the building permit.

The department will accept lumber species design stresses recommended by the U.S. Forest Products Laboratory, Madison, Wisconsin.

Sound lumber is defined as materials without structural damage such as splits, cracks, gouges, saw, rot or insect damage and with notching and borings limited as follows:

21.02 (3) (b) T-30 and T-50 Lumber

These 2" x 4" spruce-pine-fir lumber products designated by Weyerhaeuser as T-30 and T-50 are taken from machine stress rated stock graded 1450-1.3E and 1800-1.6E, respectively. These designations are intended to take advantage of better than average lumber within the stress grade level as well as more accurate stress grading procedures and equipment.

The following allowable stresses (in PSI) associated with these products are approved for use in Wisconsin.

Grade	F_b	F_t	F_c	MOE
T-30	1450	800	1150	1,300,000
T-50	1800	1175	1450	1,600,000

Any design values differing from the above are not to be accepted without complete test data from an approved testing lab wherein ASTM procedures are followed.

These products do not require a material approval as this is not a new construction material or new assembly.

21.02 (3) (d) Concrete

Chapter 22 of ACI 318 provides minimum requirements for design and construction of structural plain concrete members (those with no or little reinforcement) such as footings and foundation walls. Unless foundation walls are alternatively designed and constructed in accordance with accepted engineering practice, section 22.6.6.5 of this standard requires not less than two No. 5 bars around all window and door openings. Such bars shall extend at least 24 in. beyond the corners of the openings.

21.02 (3) (f) Roof and Floor Trusses

It is the responsibility of the inspector to verify conformance of the dwelling through the plan review process and the inspection process. It is recommended that builders or truss manufacturers demonstrate code conformance of their product to the building inspector in one of the two following manners:

1. DIRECT APPROVAL In this situation, the builder provides the structural drawings and calculations for the truss or building component directly to the building inspector for the inspector's review. The code does not require that structural drawings or calculations be provided by a licensed professional engineer or architect. The building inspector may review structural drawings and calculations for code compliance. Structural drawings and calculations are commonly sealed & signed by a professional engineer or architect and are generally considered as complying with the code.

All structural drawings and calculations shall conform to s. Comm 21.02(3) structural analysis standards. Checking of input loadings, bearing support sizes and locations, and even the span of the trusses should easily be checked to match the building design.

2. MATERIAL EVALUATION NUMBER Under this method, the manufacturer of the building component submits drawings and calculations to the Department of Commerce. The Department would review the drawings and calculations and issue an evaluation number to the manufacturer. The manufacturer provides the shop drawings with the appropriate evaluation number to the builder and/or inspector. These evaluation numbers will also be supplied on our website if available to the inspection offices from the department by way of the Material Evaluation Notices. This will serve as a means of cross-referencing the numbers to the manufacturer and the trusses.

With this method, the building inspector has to rely on the shop drawing provided by the manufacturer to determine whether or not the product on the construction site conforms to the standards. The inspector would compare the shop drawing to the truss to verify that the same quality and size of lumber, connection plates, etc., were being provided as were approved on the shop drawing. The background structural calculations need not be repetitively submitted.

21.02 (3) (g) Log Homes

This section addresses log home construction; however, log homes are often engineered and kit-produced by a manufacturer. In that case, their requirements should be followed when stricter than the code minimums. The UDC also adopts the log home construction standards

in Comm Tables 20.24-7 and 20.24-8. General guidelines for log homes that may be useful to you can be downloaded or you can order the adopted standards from the organizations referenced in the tables. The ICC standard is generally applicable to log structures, while the ILBA standard applies only to construction using handcrafted, interlocking, scribe fit construction.

21.03(1) Acceptable First Floor Exits

Question: Is it acceptable to use a ground floor exit door to help satisfy the requirement for two exits from a first floor?

Answer: Yes, assuming the two floors are connected with a stairway and the other requirements are met. In this situation, the exit separation distance would be measured from the middle of the first floor exit door to the middle of the top of the stairway on the first floor.

Question: Are first floor bedrooms required to have egress windows?

Answer: No. The code indicates two exits are required from the first floor; however, if the exit separation requirements of 21.03(1)(e) are not met then any first floor bedroom would require egress windows.

21.03(1) Earth-Sheltered Dwellings

Per the definition of first floor in s. Comm 20.07(34e), there is always a first floor, so a single-story (first floor) earth sheltered dwelling requires two exits per this section. Egress windows may not be used to satisfy requirement unless it is a small dwelling. See sections 20.07(34e) of this commentary for further discussion.

21.03(1)(e) Separation of Exits

Note that these sections require the two required exits to be separated a distance of at least one-third the longest diagonal measurement in plan view of that floor or at least 20 feet (see diagrams).

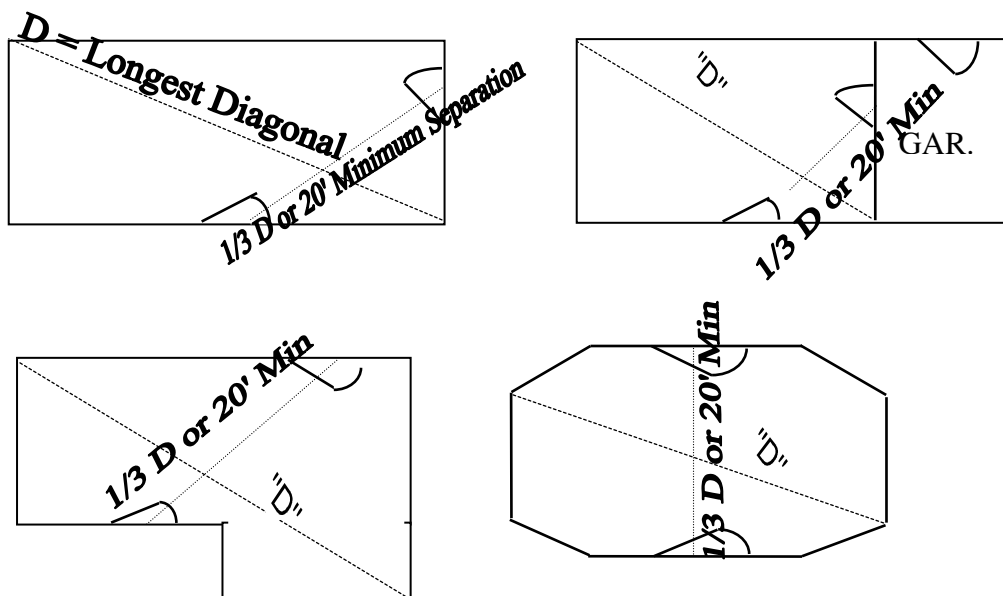

ss. Comm 21.03(1), (e) 1., & (e) 2.

SEPARATION OF EXITS

21.03(2) Second Floor Bedroom Egress

Question: If one of the second floor bedrooms has a code-compliant exit door out of the bedroom onto a deck or balcony, can the requirement for egress windows in the other second floor bedrooms be waived?

Answer: Yes, but only if the hardware on the bedroom door, which leads to the second exit is incapable of being locked from the hallway that serves as the exit path from these other bedrooms .See chapter 20.07 for 'EXIT' definition.

21.03(3) Acceptable Exits Above the Second Floor

Small third floor rooms specified under s. Comm 21.03 (3) (b) require only one stairway or ramp that leads to the second floor or lower in the dwelling. If the dwelling is fully sprinklered, only one exit is required from the third floor. Otherwise, only stairways or ramps to the second floor or grade are acceptable to meet the two exit requirements. If an exterior stair is used, access to it from the third floor shall be with a door and if the stairway terminates at the second floor, then there must be a door leading back into the dwelling or a code-compliant egress balcony to complete the exit path.

21.03(3) Exits from Attics

Question: Does the requirement for two exits for floors above the second floor apply to walk-up attics?

Answer: No - it would only apply to habitable spaces including offices, playrooms or other conditioned spaces [see s. Comm 22.10 (3)] that may be occupied. Since attics are not considered habitable spaces they need not have natural light and ventilation nor multiple electrical outlets or lights unless they are used for mechanical equipment or electrical equipment.

21.03(4) Exits from Lofts

A code-complying loft is not subject to the exiting requirements of the other subsections of this section. In other words, a loft open to a first-floor or second-floor below, only requires a single stairway or ladder (depending on area) to satisfy exiting. A loft bedroom or loft level would not require an egress window but would require natural light and ventilation the same as any other habitable space. See s. Comm 20.07(50) of the code and this commentary for a discussion of what is considered "open to the floor below."

21.03(6) Bedroom Exit Windows

Question: Can egress windows be located in sitting or dressing areas of a master bedroom suite?

Answer: This section requires egress windows in some bedrooms. However, it does not specify the location of the window within the bedroom itself. A sitting room or area located in an alcove of a master bedroom is an acceptable location for the bedroom egress window. The alcove can be considered part of the bedroom if there are no doors obstructing communication between the two areas.

Comm 21.03 (6) Egress Window Dimensions

**Minimum
20" wide x 24" high
or
24" wide x 20" high**

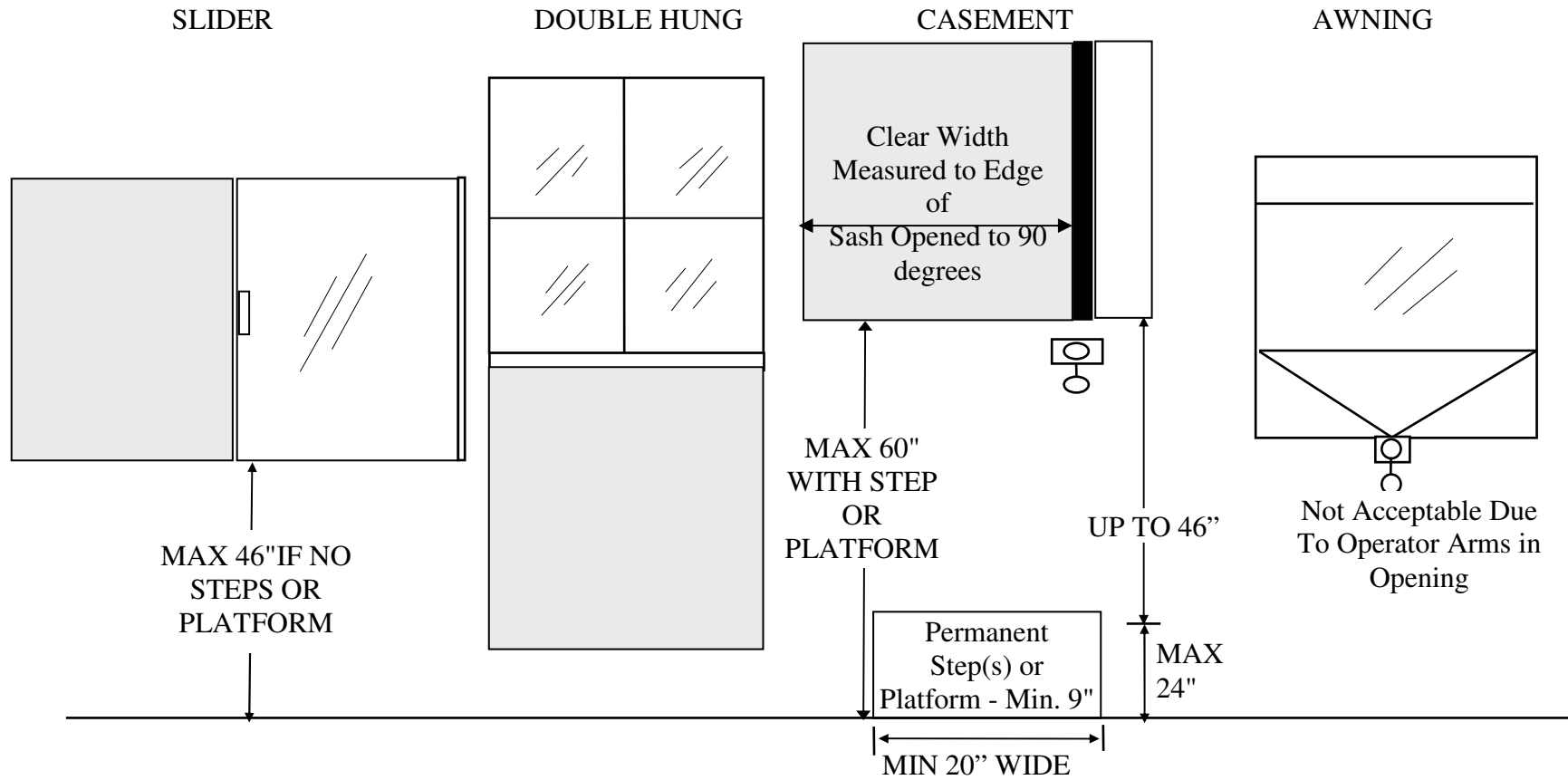

Exit Windows
See following diagram.

21.03(8) Balconies

Balconies not used for a required exit purposes may be greater than 15 feet above grade. All guardrails for balconies more than 12" above grade are required to comply with Comm 21.04(3) regarding height, in-fill or spindle and rail spacing requirements.

21.03(9) Split Level Dwellings

This section allows floor levels within 5 feet vertically of each other to be considered one floor level for exiting purposes. This does not change the definitions of the floor levels as set forth in s. Comm 20.07. Also the requirements of ss. Comm 21.03(1), 21.03(5)(b), and 21.03(6)(b) for proper separation of exits apply to the combined areas of the floor levels..

Also, any combined floor levels must all be within 5 feet of each other. In other words, a floor level that is between two other floor levels, separated by more than 5 feet, does not make all three levels into one even if exiting is from the middle level. However, the middle level may be combined with only one of the other levels.

21.035 Interior Circulation

Question: What is considered a full bath for this section?

Answer: The code is clear in requiring one full bathroom to be provided with a 2'-8" wide door. A full bathroom would contain a lavatory, water closet and bathtub or shower.

Question: What use is an "accessible" bathroom or bedroom with a 2'-8" door when it is on the second floor?

Answer: The intent of this section is to minimize future structural door framing alterations necessary to make a dwelling accessible to a physically handicapped resident. Obviously, further alterations would be necessary for the second floor situation, such as a stairway chair-lift or platform lift. Also, there may be temporary situations where a handicapped resident or guest, with physical assistance, could still make use of these second story rooms. "Accessible" does not always mean wheelchair-accessible.

Question: Can a 2'-6" flush opening pocket door be considered accessible?

Answer: This section requires, where cased or uncased openings are provided in lieu of doors, the clear width of passageway openings shall be at least 2'-6" wide. Where a pocket door is installed into a cased opening, the 2'-6" width requirement still applies. In this situation, the pocket door could not be provided with any doorstops and must open at least flush with the cased opening so that neither the door or trim infringe upon the cased opening width.

The intent of this code section is to provide a minimum 2'-6" width for disabled person use. Alternatively, a 2'-8" wide opening is required when

swing doors are installed because of the door stops and door itself infringe on the opening width such that the effective opening is 2'-6".

Question: Are interior doors required to separate rooms such as bedrooms or bathrooms from the rest of the dwelling?

Answer: No, although it is common practice to have door separating these areas, doors are not required. The minimum opening requirements in Comm 21.03 (8) must be met but doors or privacy hardware is not a code requirement.

Question: When these sections refer to a minimum door width of 2'-8", how is it measured?

Answer: The door itself should be measured - not the distance between jambs or stops.

21.035(3) Clearance Between Cabinets & Appliances

The required 30 inches of clearance between major appliances and islands, walls or built-in cabinets is measured to the face of the cabinets, not including countertop nosings.

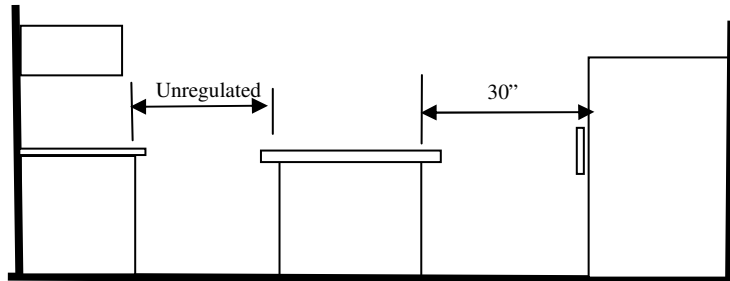

21.04(1) Non-required Stairs

Although stairways to attics and crawlspaces are not covered by the code, other non-required stairs, such as a second stairway from the first floor to a basement, are covered. Stairways are a major location of deaths and serious injuries in the home. Statistics from the U.S. Consumer Product Safety Commission (CPSC) show that one in four people will be injured and seek hospital treatment due to an injury related to stairways sometime in their lives. In 1994, the number of injuries from stairs, ramps, landings and floors was 1,879,029. This was an increase over the previous year by 11 percent (200,000-plus injuries), and was roughly equivalent to 19 percent of the total number of injuries reported in all categories for that same year.

The CPSC also estimates that the cost of home injuries in 1994 was \$94.3 billion. The cost directly related to injuries from stairs, ramps, landing and floors was \$17.5 billion.

Similarly, a study prepared for the U.S. National Bureau of Standards estimated that stair riser/tread dimensions are factors in nearly 50 percent of all stair-related injuries in the home.

21.04(1) Exterior Stairs

Question: This section applies to exterior stairs but how far away from the dwelling would this coverage extend?

Answer: The stair requirements would apply to any steps necessary to get an occupant free and clear of the dwelling and to grade, as stated in Comm 20.02(1)(g) Scope.

21.04(1)(a)2. Bathtub Platforms

Question: Do the stair code requirements apply to steps serving a bathtub platform?

Answer: Yes, unless the stairs were manufactured as an integral part of the tub. Where a step or steps are provided at a bathtub, whirlpool or hot tub, the steps are required to have a minimum 9-inch tread and maximum 8-inch riser. Where more than one step is provided, the steps need uniform risers and treads. The rim of the tub should not be considered a step unless it is a large area where occupants are likely to walk around the tub. Steps are not

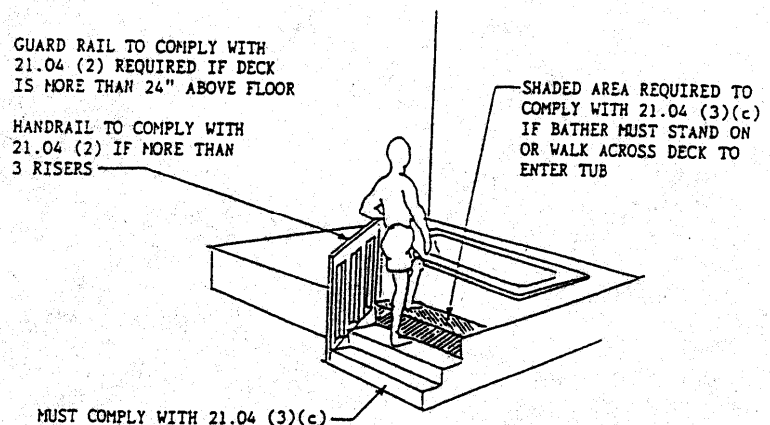
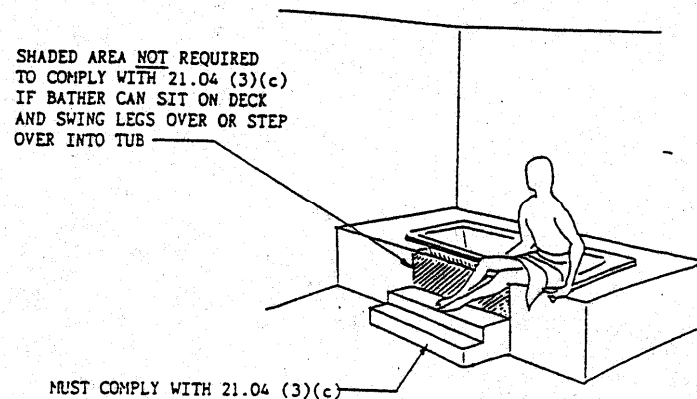

required to be provided at the base of a tub, but due to damp slippery conditions associated with tubs, steps that are provided should comply with the code.

21.04(1)(b)2. Exterior Stairs to Basements

Question: Do bulkhead-type doors and stairways need to be code complying?

21.04(2)(d)3.&4.

Answer: No, they must be code complying only if they are used AS AN EXIT, not if they are used as a service or non-required stairway. However, if they are required for egress, then verify the following items:

- landings,
- handrails,
- stairway width,
- headroom, and
- stair treads and risers.

In the case of bulkhead-type doors and stairs:

- The headroom height may be measured with the doors open, since the stairway is only usable if the doors are opened; and
- A landing is not required at the head of the stairway since this is considered an interior stairway protected from the weather.

However, a landing is required at grade outside the door.

Regarding the door(s), they must meet the exit door requirements if this is a required exit. That means it must be 2'-8" wide if there is a single door and 2'-6" each if there are double doors. If this is not a required exit, then no minimum width applies. Door headroom, at the bottom of stairs, would normally have to be in compliance with the required stairway headroom.

21.04(2)(c)3.&4. Winder Steps

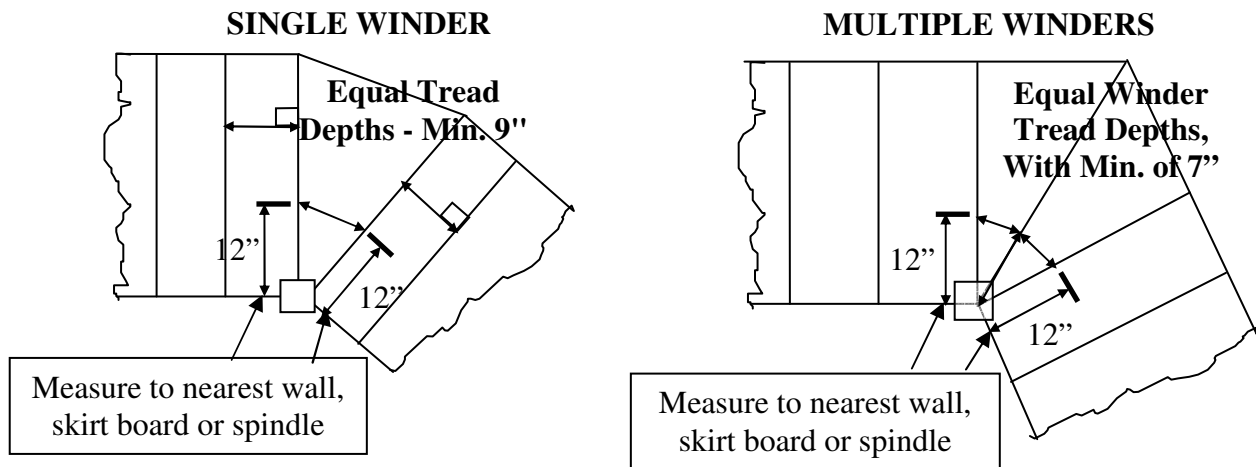

21.04(2)(d)3.&4. Planning for Stair Headroom

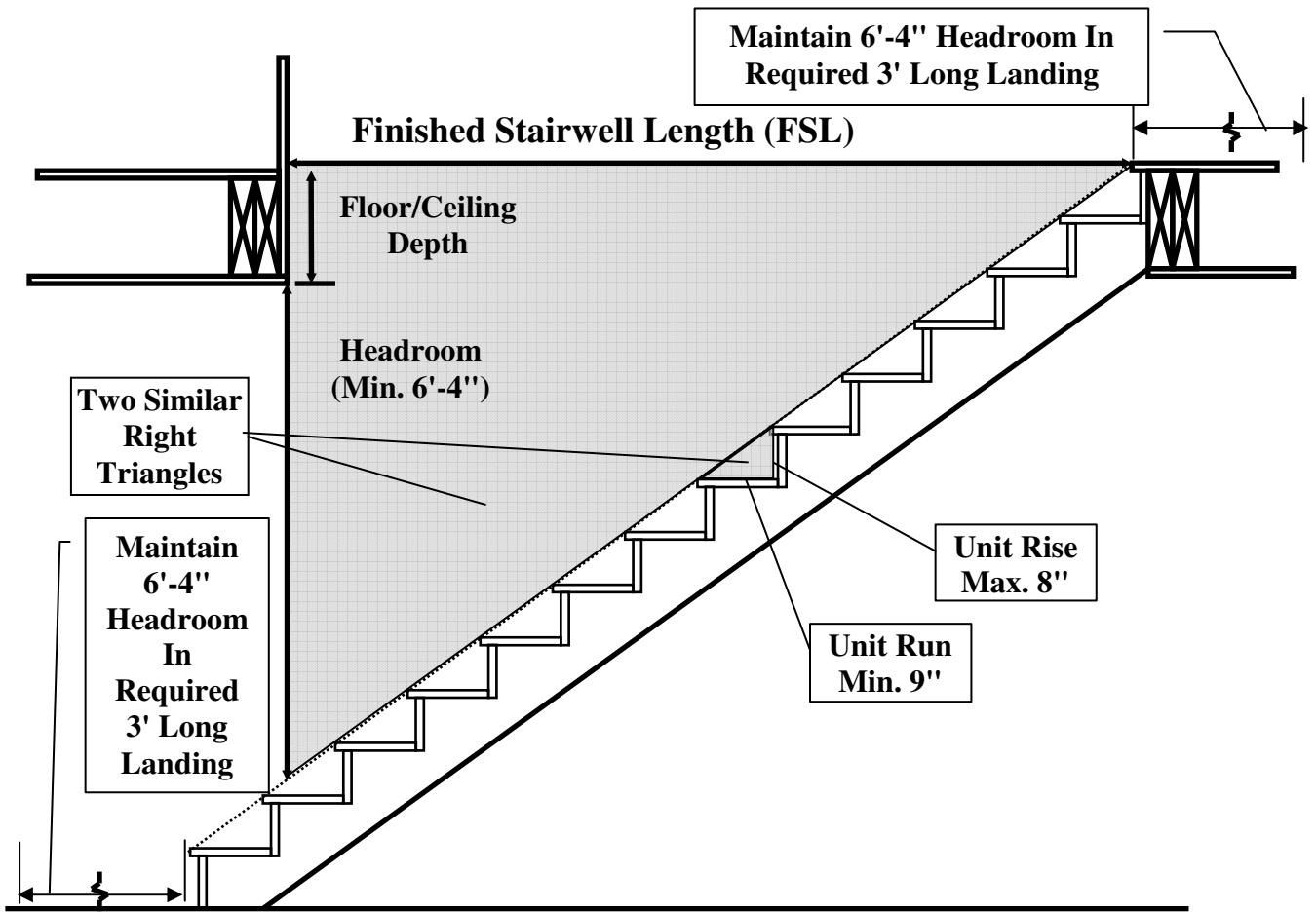

$$\frac{\text{Headroom} + \text{Floor/Ceiling Depth (HFCD)}}{\text{Unit Rise}} = \frac{\text{Finished Stairwell Length(FSL)}}{\text{Unit Run}}$$

So to solve for FSL, $FSL = \frac{\text{Unit Run} \times \text{HFCD}}{\text{Unit Rise}}$

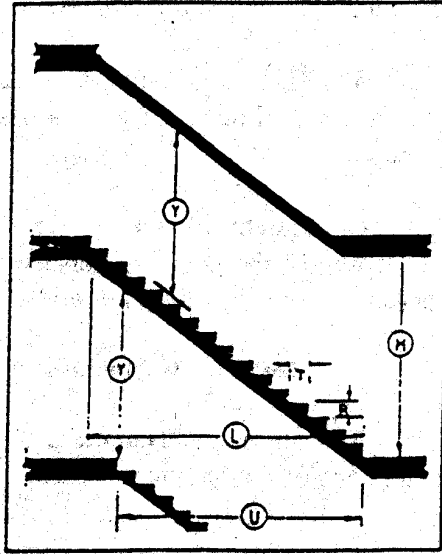

Straight Stairs

Samples and least costly requires a long hallway which may sometimes be a disadvantage. May have walls on both sides (closed string) or may have open balustrade on one side (open string).

Height Floor to Floor M	Number of Risers	Height of Risers R	Width of Treads T	Total Run L	Minimum Headroom Y	Well Opening U
8'0"	12	8"	9"	8'-3"	6'-4"	8'-1"
	13	7 3/8" +	9 1/2"	9'-6"	6'-4"	9'-2 1/2"
	13	7 3/8" +	10"	10'-0"	6'-4"	9'-8 1/2"
8'6"	13	7 7/8" -	9"	9'-0"	6'-4"	8'-3"
	14	7 5/16"	9 1/2"	10'-3 1/2"	6'-4"	9'-4"
	14	- 7 5/16" -	10"	10'-10"	6'-4"	9'-10"
9'0"	14	7 11/16"	9"	9'-9"	6'-4"	8'-5"
	15	-	9 1/2"	11'-1"	6'-4"	9'-6 1/2"
	15	7 3/16" + 7 3/16"	10"	11'-8"	6'-4"	9'-11 1/2"

21.04(2)(e)1. Tread Height and Depth Uniformity

Within a stairway flight, the greatest tread depth may not exceed the smallest tread depth by more than $\frac{3}{8}$ inch and the greatest riser height may not exceed the smallest riser height by more than $\frac{3}{8}$ inch. Once an intermediate landing occurs, a new flight starts and new riser and tread dimensions may be used.

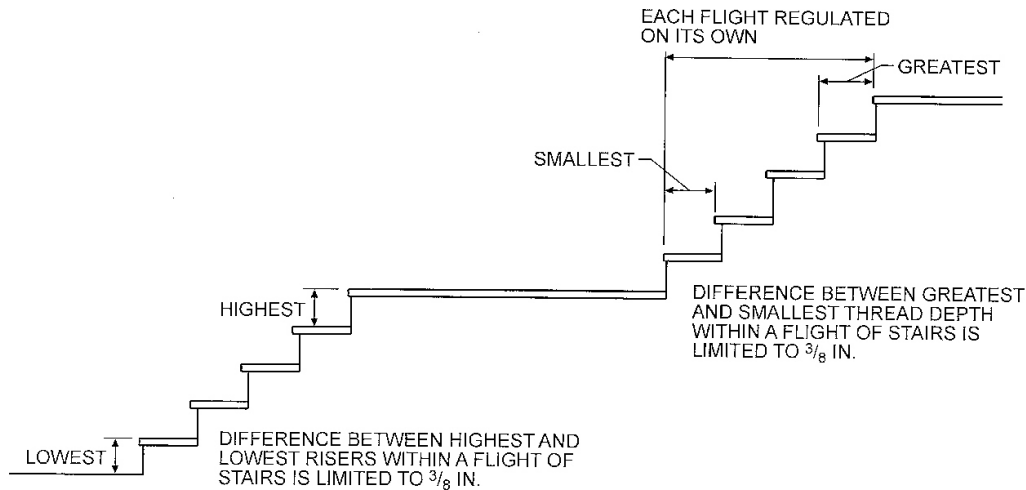

Question: How is tread and riser measured for the purposes of this requirement, especially taking into account the variety of finish materials used?

Answer: The tread and risers should be measured prior to application of carpeting. Measurements should be taken to hard surface finish materials. This alleviates problems encountered when the homeowner changes carpeting materials. If the carpeting is already in place, the inspector should estimate the thickness of carpeting and padding to determine compliance. The inspector should walk up and down the stairs, as well, to determine what, if any, tripping or falling hazard exists.

Question: At an exterior door (or an interior door, such as the 20-minute rated door, between the house and garage) a threshold separates the main floor level from the stair or landing, either up or down. Is the height of the threshold included in the riser height when you are determining if all risers are uniform?

Answer: No, you always measure from hard surface to hard surface. This means from the floor level to the landing or tread, even if the threshold “could” be stepped on, it is not included in the height of the riser. Remember that carpeting is not a hard surface even if is indoor/outdoor type material.

21.04(3) Handrails or Guardrails

See handrail cross-section diagrams in the UDC Appendix (approximately page 140).

Question: At the time of occupancy, a sliding patio door installed in an exterior wall is viewed by the inspector without an exterior deck, landing, stairway or

21.04(4)(a)

platform. The floor to grade elevation difference is greater than 8 inches. Is this okay since two other exit doors could provide exiting from the dwelling and the elevation difference is less than 24 inches?

Answer: No. The presence of the door, whether required or not, is installed to allow exiting and movement between areas. There is an elevation difference from the floor to grade in the exit path so a stairway or landing platform is required per s. Comm 21.04 prior to occupancy. However, if the door was substantially fastened closed with hardware and screws that would not allow it to be opened more than 4", then it would not be considered a door and steps would not be required in the interim until a proper exit path is provided.

Question: Does a non-required guardrail serving a porch less than 24 inches above grade need to comply with the code?

Answer: This section does not require the guardrail where the porch is less than 24 inches above exterior grade; therefore the height and other specifications are not required for the guardrail installed. The designer may still want to install the guardrail per code to alleviate concerns that the installation of a non-required guardrail meeting less than the minimum specifications may provide a false sense of safety for the building occupants.

Question: Does a window well require a guardrail around it?

Answer: No.

21.04(3)(c) Measurement of Grade Differences for Guardrails

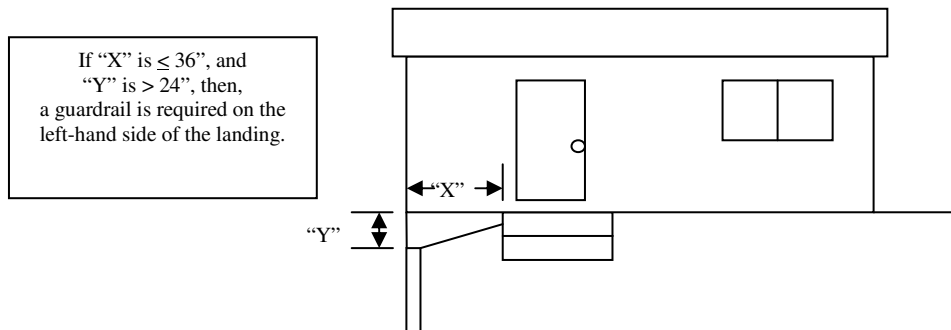

21.04(4)(a) Irregular Landings

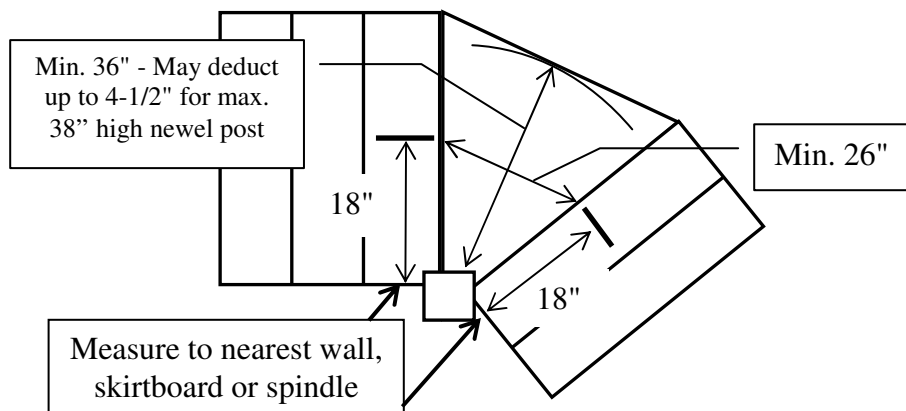

21.04(4)(a) Projections into Minimum Stair Landing Width

The 4 1/2-inch maximum allowed projection of handrails or trim into the width of a stairway on each side also applies to both sides of a landing since the landing is part of the stairway. Also see Comm 21.035(2)(b) infringements permitted at hallways.

21.04(4)(c) Stair Landings at Sliding Doors

Question: Is a landing required at the top of a stairway leading to a sliding door?

Answer: No, if this is an interior door. The exception under s. Comm 21.04(4)(c)1.a., which applies here, eliminates the landing if the door does not swing over the stairs. Obviously, a sliding door could not swing over the steps. This exception applies to both opaque and glazed doors.

It depends, if this is an exterior door, the exception under s. Comm 21.04(4)(c)1.c., eliminates the landing if there are no more than three risers and if the door is a sliding glass door. Otherwise, a landing is always required per the introductory paragraph.

Question: Is a landing required at an exterior, glazed, swinging patio door?

Answer: If the exterior grade elevation is more than 8 inches lower than the interior floor elevation, a landing is required. The sliding glass door exception does not apply to swing exterior glass doors regardless if they swing in or out of the dwelling. The argument of the door being glazed permitting occupants to see a elevation change or step conditions on the other side of the door does not hold true due to drapes or other visual obstructions frequently being provided on the door.

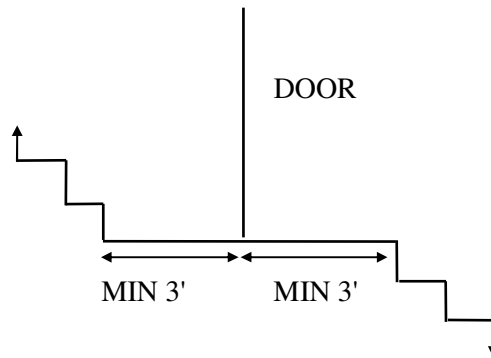

Exceptions

Interior Stairs (Garages and protected porches are interior spaces):

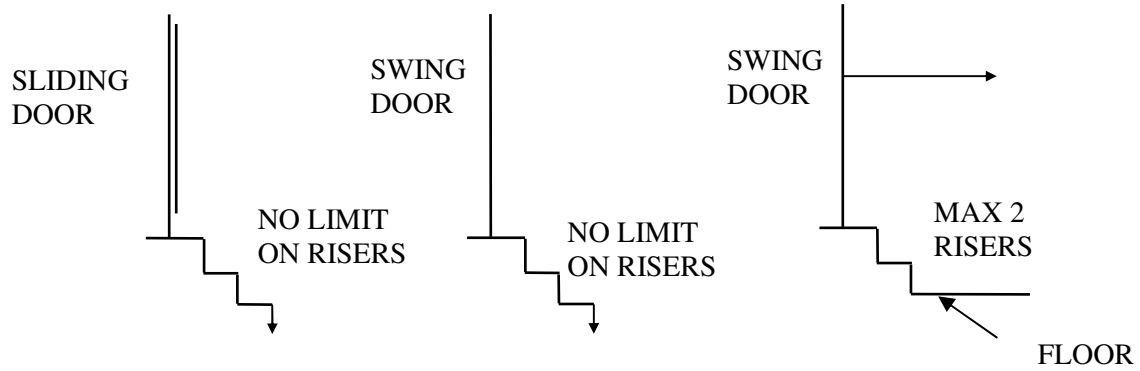

Exterior Stairs

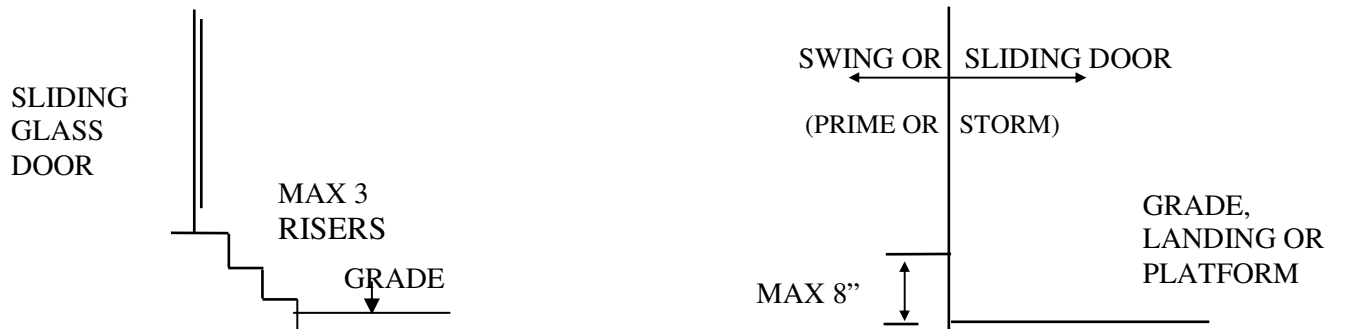

21.042(2) Ladder Treads

Ladder treads are measured the same as stairway treads - horizontally from nosing to nosing.

21.042(6) (b) Top Ladder Tread

This section is requiring that the top tread's (first tread below the floor level) back edge be at least 7 inches from the wall in front of it. This ensures adequate toeroom and still allows a full depth tread.

21.05(3) Safety Glass

Safety glazing must now meet 16 CFR Part 1201. The use of glazing meeting ANSI Z97.1 is no longer an acceptable safety glazing material. It is important to note that state statutes s. 101.125 also requires safety glazing. In addition, the Federal Consumer Product Safety Commission (CPSC) in its regulation 16 CFR Part 1201 sets a minimum for safety glazing requirements for doors and tub & shower enclosures that states may only exceed with their requirements. While most of the items covered by these requirements are glazed in the factory, local inspectors may become involved when site-made doors are used, re-glazing is done, old doors are reused, sidelights are site-installed or when the manufacturer fails in its obligations. Following are some questions and answers on these various requirements.

Question: Why is safety glazing necessary?

Answer: The CPSC found that prior to its rules in 1974 that approximately 73,000 injuries related to architectural glazing were treated annually in hospitals nationwide. Almost half were under age 14. The worst accidents are those where the victim breaks the glass on impact and then he or she rebounds back. On the rebound, the shards of glass get caught under the skin and then severely rip it as the victim continues rebounding.

Question: How can I identify safety glass?

Answer: It will normally have a permanent label in the corner stating that the glass meets 16 CFR Part 1201. You may request documentation from the manufacturer if the label is not present. Safety glazing is classified by the manufacturer as either Category I for use only in doors where the glazing is less than 9 square feet or Category II for all ther uses.

Question: What are the different types of glazing and which may be acceptable?

Answer: Tempered glass may be acceptable. It is produced by reheating glass and then suddenly cooling it. It is four times stronger than regular annealed glass. It cannot be cut after tempering so dealers will often need to custom order it from a tempering facility. It breaks into small pieces when broken. Laminated glass may be acceptable. It consists of two or more layers of glass bonded to a tough resin interlayer. It can be cut or drilled.

21.05(3)

Wired glass is generally not acceptable in areas where safety glazing is required unless it is labeled as meeting CPSC 16 CFR Part 1201. It would typically need an added layer of resin to meet that standard.

Heat-strengthened glass is not acceptable. It is produced similarly to tempered glass but is cooled slower. As a result, it is only twice as strong as regular annealed glass. It can be cut or drilled.

Annealed glass is not acceptable. It is regular glass that may also be known as flat or primary glass. Also not acceptable are plate, float, sheet and patterned glass. These are easily cut and drilled.

Plastic glazing is not considered glass so it is not subject to the safety glazing requirements.

When safety glazing is required, all layers of a multi-layer assembly (e.g., insulated glass) must be safety glazed.

Question: Is safety glazing required in glazed sidelight panels on both sides of a sliding patio door unit which has one fixed and one operating panel?
Answer: Yes, the CPSC requires both panels of a patio door unit to be safety glazed, whether they are fixed or operating. Therefore the Wisconsin code requirement applies to glazed sidelight panels located on either side of both patio door panels.

Question: Are these requirements retroactive?
Answer: While the UDC only applies to one- and two-family dwellings built since June 1, 1980, both the CPSC and state statutory requirements are retroactive to any re-glazing work done in all types and ages of structures.

Question: Can leaded, stained glass be used where safety glass is required?
Answer: Yes, based on the state statutes and CPSC regulations, this would be acceptable.

Question: Does the UDC require safety glass in panels or windows that come down near the floor but not next to a door?
Answer: No, although the Commercial Building Code, various model codes and good design would require safety glass in such situations, the UDC does not.

Question: Is safety glass required in overhead garage vehicle-passage doors?
Answer: No. The safety glazing requirement is for doors that are primarily used for human passage.

Question: Is safety glass required in skylights?
Answer: Not by the UDC or CPSC, although the Commercial Building Code requires its use in skylights. However, the 30 or 40 PSF snow load requirement of the UDC must be met.

Question: Are glass blocks or glass block windows used in a tub or shower area in compliance with the safety glazing rules?

Answer: Yes, first the individual units normally don't exceed the minimum dimensional requirements for safety glazed units. Secondly, the process used in the manufacturing of glass block puts them into the category of a masonry unit and therefore they do not need to meet the requirements for safety glazing.

21.05(3)(b) Safety Glass Around Tubs

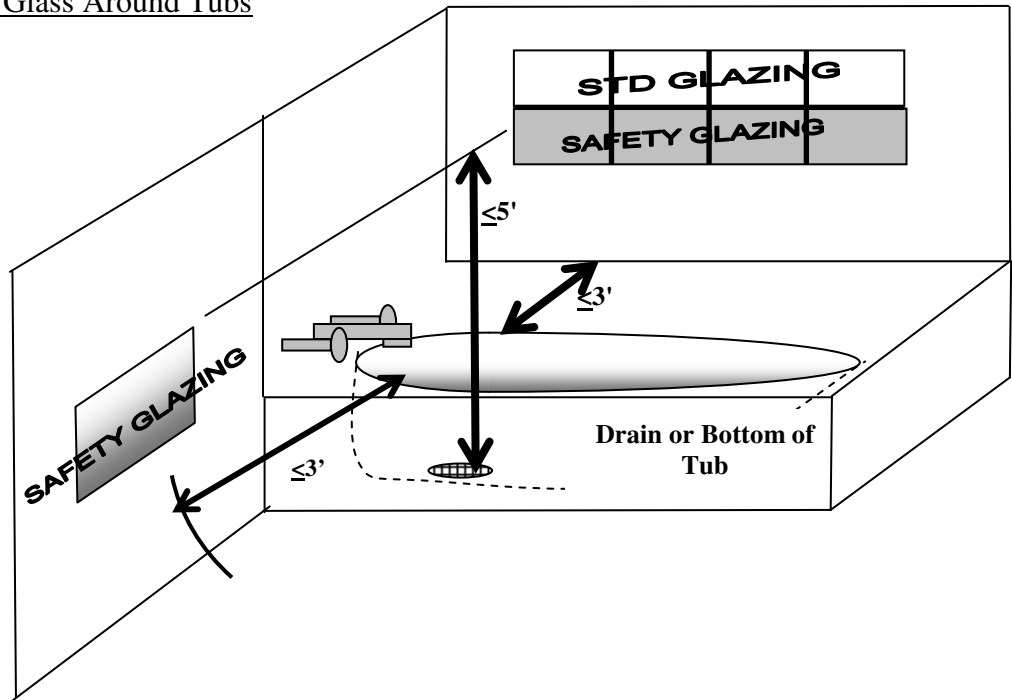

21.05(3)(b) Safety Glass Around Stairs

Plan View

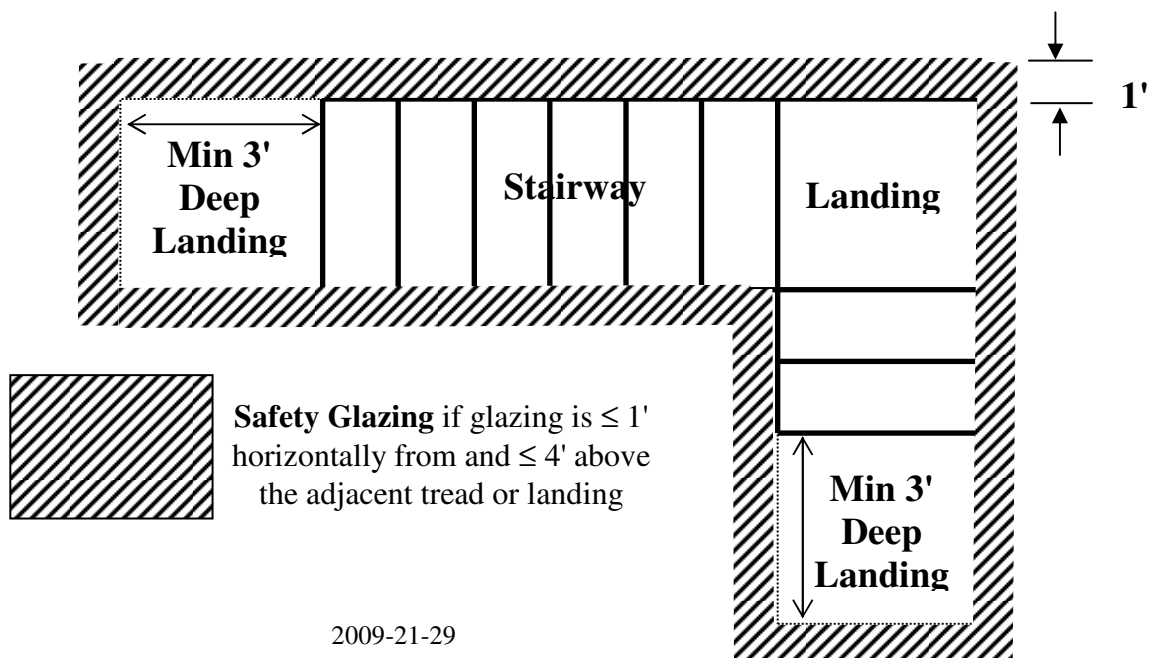

21.08

21.06 Ceiling Height

Question: Does a basement have to comply with the 7-foot minimum ceiling height requirement?

Answer: It only does in those 'habitable' areas of the basement that contain rooms used for sleeping, living, dining, kitchens, hallways, bathrooms and corridors. From a practical standpoint, most basements will contain some of these uses initially or after the basement is finished-off in the future. Some foresight by the builder or owner is advisable, since changing ceiling height is not a practical building alteration.

Question: May a ceiling fan or light fixture encroach on the required ceiling height?

Answer: A ceiling fan or light fixture may encroach similar to a beam or ductwork - no more than 8 inches below the required ceiling height; therefore, 6'-4" minimum clearance maintained between fan or other obstruction and the floor.

21.07 Attic and Crawl Space Access

Question: Can access be provided from outside the building, such as an outside vent or scuttle?

Answer: Yes, however, any area of 150 square feet or more must still comply with the minimum opening size of 14" x 24". This means if you have a home with more than one attic space separated by a cathedral ceiling, two openings would be needed.

Question: Do crawlspaces built with less than 18 inches of clearance or over concrete slabs need access?

Answer: No access required; however, if area is outside the dwelling thermal envelope, venting is required.

21.08 Zero Lot Line Dwellings

See appendix for explanatory drawing about adjoining, separate dwellings.

21.08(1)(d)2. Attic and Crawl Space Access

Question: What kind of hardware is necessary on an attic access door that is located in the separation between a garage and dwelling area?

Answer: The cover or door is installed so that it is permanent (non-removable) with hardware to maintain it in a closed position with latching hardware to maintain. Self-closing hardware is not required.

21.08(1)(c)(d)2. Attic and Crawl Space Access

Question: How do you measure the distances indicated in Table 21.08 regarding dwellings and attached/detached garages and accessory buildings?

Answer: Fire-rated construction may only be required in situations of a common house/garage wall or of adjoining house and garage walls that are less than 10 feet apart when measured perpendicularly from the house walls. Per Table 21.08, fire-rated construction would not be required if the distance between walls is 10 feet or more. The fire-rated construction is required only in those portions of either wall that does not meet the above test. In attached connecting breezeways or porches where there is no common wall but a common roof, the entire fire wall separation is required. This follows from the requirement that any fire separation shall extend from the top of the concrete or masonry foundation to the underside of the roof sheathing or ceiling. (See diagrams.)

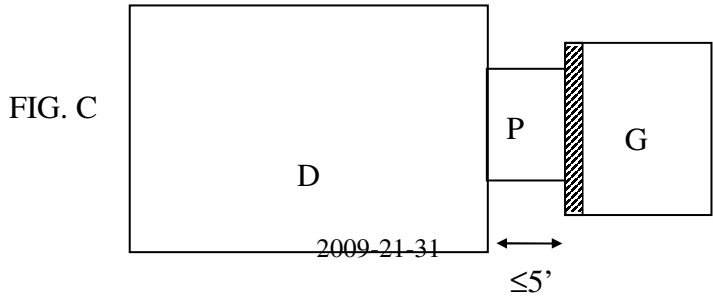
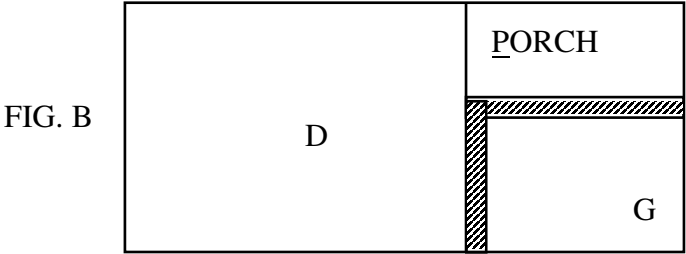
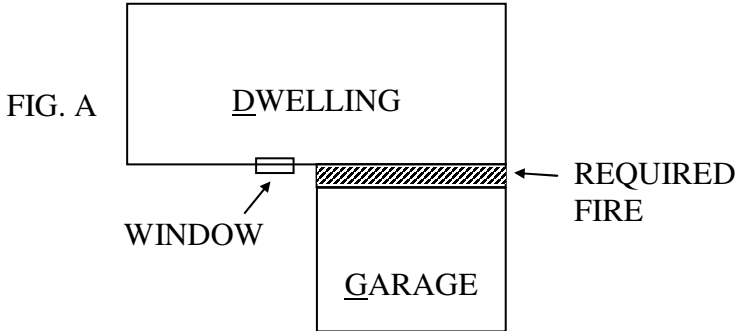

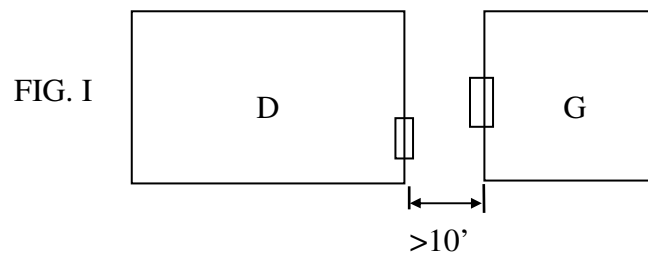
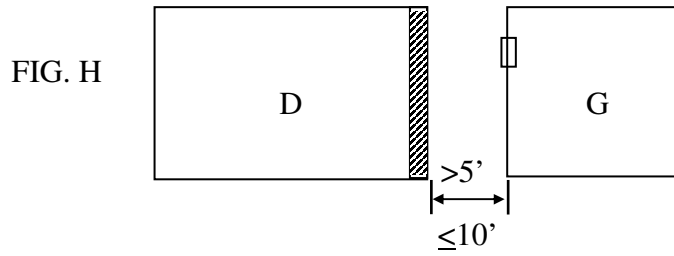
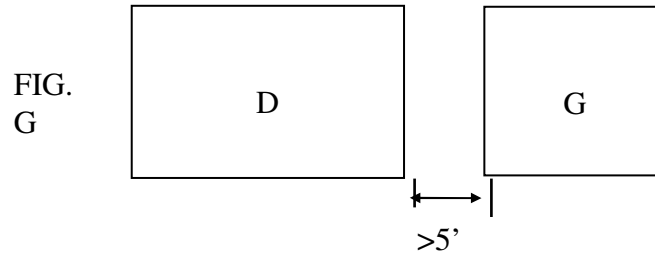
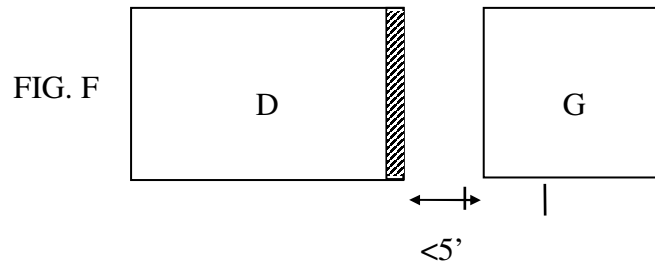
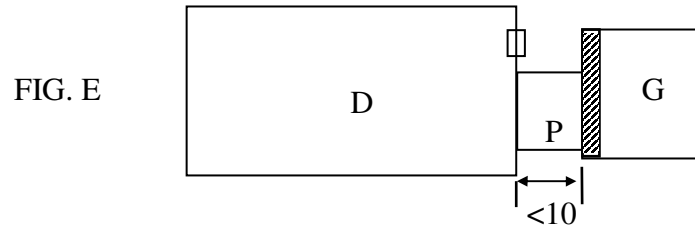
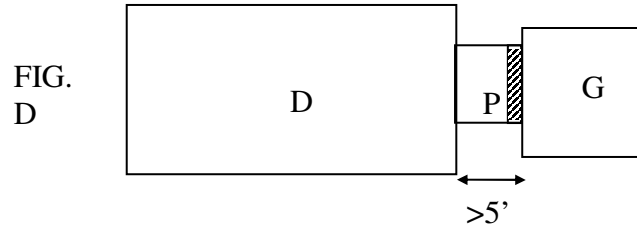

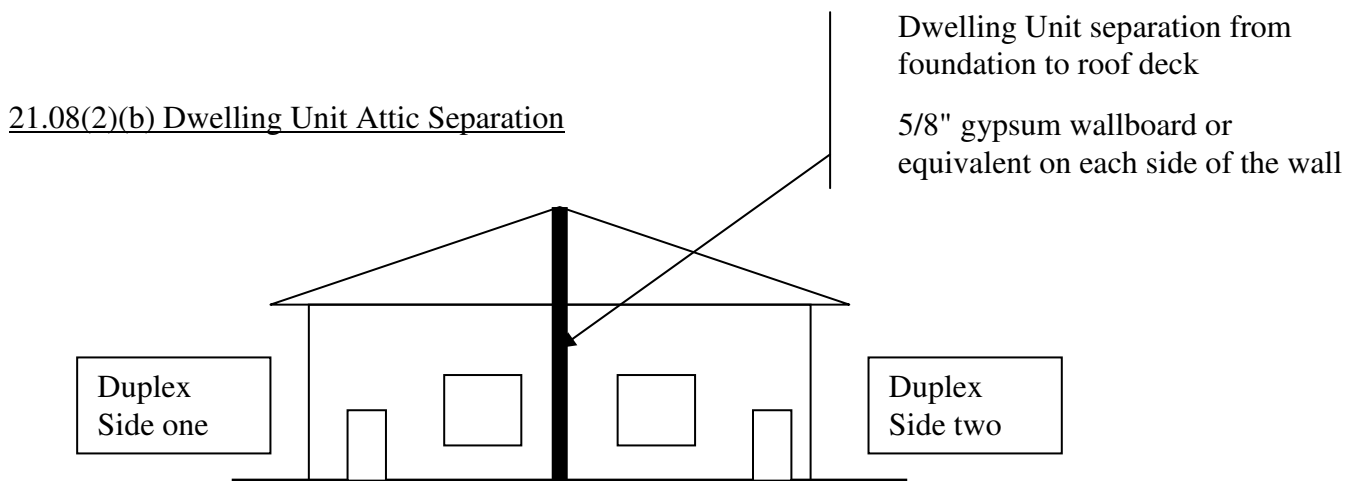

METHOD #1
Comm 21.08 (2) (b) 1.

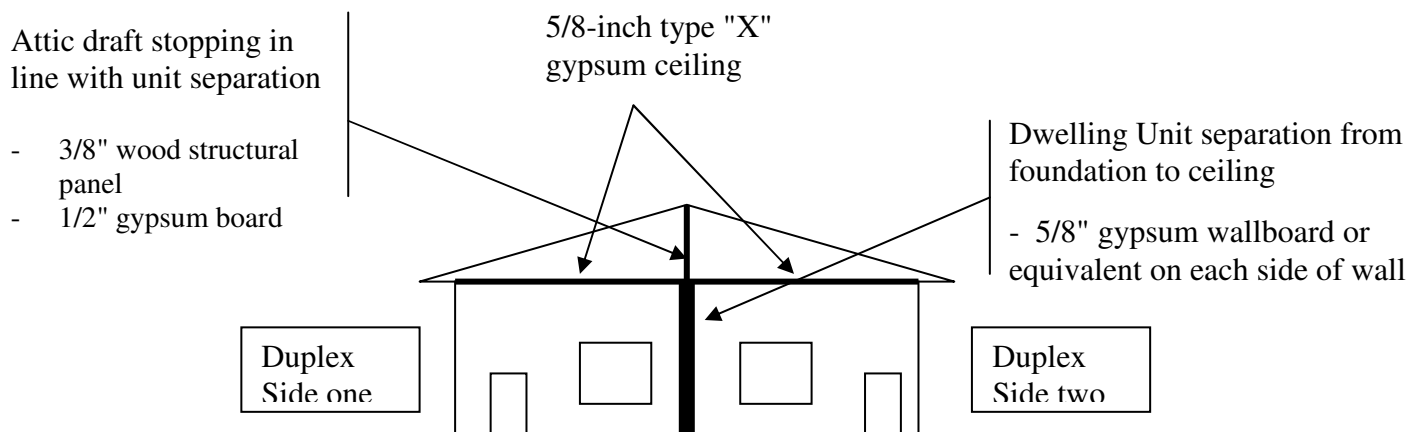

METHOD #2
Comm 21.08 (2) (b) 2

21.085(1) Fireblocking of Tubs and Showers

Question: How should tub/shower units be fireblocked?

Answer: For most units, there should be no need for fireblocking since interconnected vertical concealed spaces do not require fireblocking. However, if the unit had a canopy with a dropped soffit, then the fireblocking requirements would apply to the interconnected vertical and horizontal concealed spaces, similar to kitchen cabinet soffits. Also, the floor below a tub should be fireblocked if it allows air/fire passage between levels within concealed spaces.

21.085 Fiberglass Insulation as Fireblocking

21.09

Question: Is fiberglass insulation acceptable as a fireblocking and draftstopping material?

Answer: As a fireblocking material, yes. As a draftstopping material, no. This section allows other noncombustible materials in lieu of the traditional 2 inch nominal wood or drywall firestops. Unfaced fiberglass batt insulation has passed the E-136 (ASTM) test for non-combustibility. Therefore, such insulation will be allowed as firestopping if it is tightly packed such that it will be held in place

At ceiling and floor levels in platform framing. The material used for this application is framing lumber.

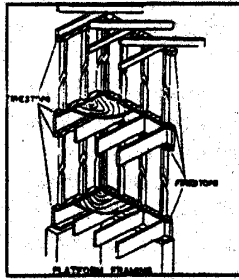

Firestopping needs to be installed below the dropped ceiling to prevent rapid movement into a large, open area. Material used is to be framing lumber.

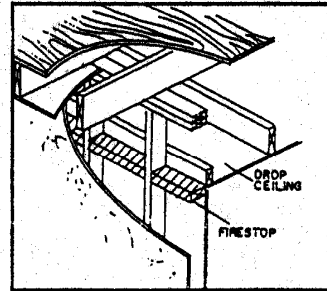

When remodeling an old house, beware of balloon framing. This framing technique is a fire hazard and must have firestops applied. The material used here is framing lumber. Balloon framed homes with cellulose insulation blown into the walls are much more firesafe than those with open cavities or more air permeable insulations.

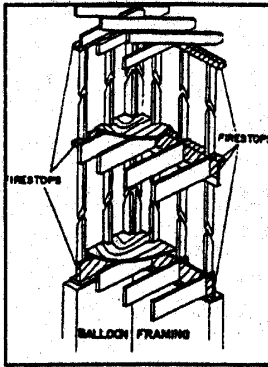

The two firestops applied to stair stringers are critical to the firestopping system and prevent the fire from moving quickly to the area between the floors. Material is to be boards, cement board, or plywood.

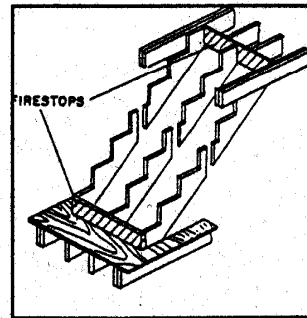

Firestopping at the soffit is critical to preventing a fire from rapidly moving into the open attic area. Material used is to be framing lumber.

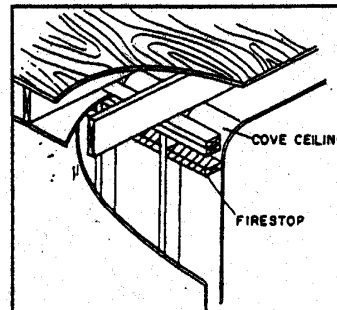
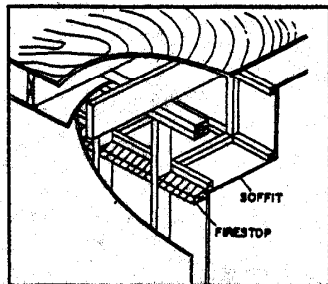

Cove ceilings provide a challenge because there is insufficient wood to stop the fire against the curvature of the ceiling. Firestops must be applied against the vertical portion of the wall. Material used is to be framing lumber.

Comm 21.11

21.09 Smoke Detectors

Question: If a contractor or owner wants to have additional smoke detectors over and above the minimum required by the Code, can they be battery-operated or must they be hard wired into the required system(s)?

Answer: Yes, if an owner wants a battery-operated smoke detector in every room or closet, they can do that.

Question: Should smoke detectors be connected to a separate, dedicated circuit or can they be tied to any lighting or outlet circuit?

Answer: Unlike fire alarm systems in commercial applications, the Department's recommendation is to connect the smoke detectors to a common lighting circuit and be connected ahead of any local switches. That way, if the circuit breaker trips, the owner will be aware that his smoke detector and alarms are not operational because his hallway or kitchen (etc.) lights aren't working.

Comm 21.095 Carbon Monoxide Detectors

See the code Appendix for new CO detector requirements for licensed tourist rooming houses.

Comm 21.10 Protection Against Decay and Termites

Question: An interior wood frame wall is placed on a continuous concrete footing in the basement and is used in place of a beam for support of the floor system above. The top of the footing will be level with the basement floor. Does the sole plate of this wall have to be pressure treated with a preservative or be decay-resistant lumber?

Answer: Subsection Comm 21.10 (1)(g) states that wood used in basements for bearing walls shall comply. This is a bearing wall and, therefore, must comply.

Comm 21.11 Foam Plastic Insulation Protection

The department has been asked whether foam plastic sheathing located on the gable ends of an unoccupied attic must be directly covered with a thermal barrier. The foam plastic is required to be separated from the living space by a thermal barrier. In this case, if a thermal barrier is located on the ceiling, such as the interior gypsum drywall, the foam plastic is adequately separated from the living space and no direct protection is required.

We have also been asked if foam plastic on the interior of a crawlspace needs to be covered. If the crawlspace does not openly communicate with an adjacent basement or other living space, then the floor sheathing is adequate to separate the foam plastic from the rest of the dwelling. However, if the crawlspace adjoins a basement or other space so that there was free air flow between the two, then the foam must be covered.

Another question has been raised about the use of foam plastic insulation on the interior of return air ducts. Sections Comm 21.11 and 23.08 prohibit the placement of unprotected combustible foam plastic on the interior of supply and return air spaces.

Comm 23.08(2)(a) requires ducts to be constructed of or lined with a noncombustible material. An exception is made for unlined wood joists or stud spaces. Therefore, combustible foam plastics located on the interior of duct spaces must be protected by a noncombustible 15-minute thermal barrier.

Finally it has been asked if foam insulation in attached garages needs to be protected. Yes it does because the requirement applies to any space where occupants may be present or to which they may be indirectly exposed.

An important exception to the protection requirement in the Celotex Thermax brand foam insulation which has received a Wisconsin Building Materials Approval (#200614-I) to be installed without protection. This is based on diversified testing that simulates actual fire conditions.

Subchapter III — Excavations

21.125 & 21.126 Erosion and Sediment Control and Storm Water Management.

See the UDC Appendix for erosion control and storm water management information, including references to DNR & DOT websites for design standards. Also see Commerce – Safety & Buildings website for Soil Erosion program information, to get the latest information on design and requirements during and after dwelling construction.

Subchapter IV – Footings

21.15(1)(e) Floating Slabs or Similar Shallow Foundations

Comm 21.15(1)(e) requires structures with frost foundations to be structurally isolated for the entire building height from portions of the building structure constructed on floating slabs. This is needed so that portions that do not move will not separate from those that “float” under frost forces, as well as so that exits are not obstructed by relative movement of dwelling portions. A structural engineer could have some details that will work for the different types of materials used at these locations that need a different type of connector. Slip-joints can permit vertical deflection to occur, while maintaining horizontal load integrity of the structure. Load paths will be critical to determine what is acceptable there and what will not be permitted for connections.

21.15(2)(f) Deck Footings

Decks that are used in the required egress paths, even though physically separated, must comply with the UDC. Footings must be designed to carry the loads of the deck. They may be supported by frost footings or by a floating slab per Comm 21.15(2)(e). If the latter option is chosen, then care should be taken to avoid differential settlement or frost heave that could block the egress path. For the latter concern, a stepdown may be desirable.

21.15(2)(a) Unstable Soil

21.15(2)(f)

Forming of a continuous footing is required if you encounter an unstable soil. Per the note, an unstable soil would be one that can not support itself at an approximately 90 degree angle for the full depth of the footing. Examples of unstable soils would be sands or gravels.

21.15(2)(e) Floating Slabs

Section 21.16 generally requires a 48-inch footing depth to prevent frost damage. There are some exceptions to allow lesser footing depths provided measures are taken to prevent frost heave damage to the structure. Some measures which may be considered to help prevent damage, if over and above the code minimum requirements, include:

- Verification of good soils (well-drained, granular) which may be less subject to retaining water which may freeze and expand.
- Additional drainage at the affected footing in conjunction with good surface drainage.
- Providing reinforcement in the affected footing and/or foundation wall.
- Providing reinforced perimeter grade beams in slab-on-grade construction.
- Providing a mechanical tie or continuous reinforcement to bind the stoops or ramps to the foundation wall to resist relative movement. This would help prevent obstruction of exit doors or gaps at the wall to stoop interface.
- Overdesigning the foundation or structure to recognize the potential for some soil-caused deflection.
- Insulate the soil around the building perimeter with foam board laid horizontally just below the ground surface.

Most times a qualified engineer should make the determination which of the above, or other, measures is inherent in the situation or may be required to gain code compliance. The engineer's report should be submitted to the local inspector for approval.

21.15(2)(f) Deck Column Footing Size

Deck footings are required [s. 21.225(2)] to be designed with a bearing area equal or greater than the area required to transfer live and dead loads to the supporting soil without exceeding the bearing value of the soil. In lieu of a designed footing, the code required minimum size or a column footing of 24" x 24' x 12" thick should be used in accordance with Comm 21.15(2)(b). In designing a column footing for a deck, the following steps should be utilized:

- 1) Calculate the tributary area for floor and any roof area that the column carries.
- 2) Multiply the floor area by the code required live load and actual dead loads. Do the same for any roof area.
- 3) Divide the total load from 2) by the this site's allowable soil bearing value listed in the Table at the end of s. Comm 21.15(3) to find the minimum footing size in square feet.

- 4) To provide adequate spread of the load through the concrete or gravel footer, its thickness should be at least one-half of its diameter, but in no case less than 8".

21.16 Frost Penetration

Question: How does one determine if the local frost penetration is greater than the 48-inch minimum requirement by code?

Answer: In most cases, you will find that the average frost depth does not exceed the 48-inch depth. A good source for the average local conditions of frost is to check with the people involved with the installation of utilities or grave digging.

21.16(2)(a) Frost Protected Shallow Foundations

Question: Are frost-protected footings allowed and what standards must be followed in the construction of footings or slabs-on-grade without going below frost levels?

Answer: Yes. Frost-protected footings are allowed and by Comm 21.16(2)(a) are to be designed to ASCE-32-01 standard adopted with 2009 code changes. Frost-protected footings (FPF) is an internationally recognized and accepted technique of protecting slab-on-grade foundations of heated buildings against frost action. The FPFs use rigid horizontal perimeter insulation to reduce heat loss from the ground around the dwelling. This heat keeps the ground from freezing and frost action on the structure. The FPFs have been used in Scandinavian countries since the 1950s and more recently in the United States. See the UDC Appendix for a public domain version of this design methodology. Note that if the heated building design is chosen, the current and future owners need be made aware of the need to keep the dwelling heated in the winter to avoid frost damage.

21.17 Determination of Drain Tile Need

Where municipalities exercise jurisdiction over requiring drain tile within their community, they should provide sufficient notice to the building permit applicant by indicating to the applicant at the time that the plans are approved how the municipality handles enforcement of drain tile. This means that the municipality, plan reviewer, or inspector should at the time the plans are approved indicate whether or not the community will require drain tile to be provided with Comm 21.17, not require drain tile to be provided, or will make a determination as to whether or not drain tile will be required upon an inspection visit to the excavated site. This allows the communities to either have a blanket policy of a requirement or non-requirement for drain tile, and still allows them the flexibility to make that determination upon viewing the excavation, wherein they can determine soil types and sometimes water elevation. It is the department's position that for the drain tile requirement, the decision should be made as early on in the permit, plan review, inspection process as possible and that decision should be documented in review comments or inspection reports.

In response to questions and concerns regarding work continuing after an inspection has not been carried out after the 2-days after date of notification requirement, municipalities

21.17

and inspectors should inform the builder or owner that they are proceeding at their own risk, and at the time the municipality or inspector makes the inspection they may still require the drain tile to be provided in accordance with Comm 21.17.

A municipality may use various criteria other than a soil test report (per s. Comm 21.17(1)(b) to determine where drain tile systems are required. Such criteria may include county soil maps, direct observation of standing water in the excavation, and experience with other sites in the locality. There is substantial discretion given to the local inspector. It is recommended that the criteria for this local discretion, or municipal policy, be uniformly applied within the municipality and expressed to builders before construction, such as at permit issuance.

Where no local permit is required for an addition, the code requires the owner and builder to install drain tiles where a soil test indicates periodic or seasonal groundwater at the footing. Often times such homes are also in un-sewered areas. The soil test report for a private sewage system will indicate depth to seasonal groundwater. This report may be used to determine dwelling drain tile requirements if the house site is close to and is similar in soil and drainage characteristics to the private sewage system on that site.

If a private sewage system soils report is not available or applicable, then the owner or builder may retain a qualified soils consultant (engineer, certified soil tester) to determine groundwater depth or rely on the experience of other projects in the area, if relevant.

TABLE 1
TYPES OF SOILS AND THEIR DESIGN PROPERTIES

Soil Group	Unified Soil Classification System Symbol	Soil Description	Allowable Bearing in Pounds Per Square Foot with Medium Compaction or Stiffness⁴	Drainage Characteristics²	Front Heave Potential	Volume Change Potential Expansion
	GW	Well-graded gravels, gravel sand mixtures, little or no fines.	8000	Good	Low	Low

Soil Group	Unified Soil Classification System Symbol	Soil Description	Allowable Bearing in Pounds Per Square Foot with Medium Compaction or Stiffness⁴	Drainage Characteristics²	Front Heave Potential	Volume Change Potential Expansion
Group I Excellent	GP	Poorly-graded gravels or gravel sand mixtures, little or no fines.	8000	Good	Low	Low
	SW	Well-graded sands, gravelly sands, little or no fines.	6000	Good	Low	Low
	SP	Poorly-graded sands or gravelly sands, little or no fines.	5000	Good	Low	Low
	GM	Silty gravels, gravel-sand-silt mixtures.	4000	Good	Medium	Low
	SM	Silty sand, sand-silt mixtures.	4000	Good	Medium	Low
	GC	Clayey gravels, gravel-sand-clay mixtures.	4000	Medium	Medium	Low
	SC	Clayey sands, sand-clay mixtures.	4000	Medium	medium	Low

Soil Group	Unified Soil Classification System Symbol	Soil Description	Allowable Bearing in Pounds Per Square Foot with Medium Compaction or Stiffness⁴	Drainage Characteristics²	Front Heave Potential	Volume Change Potential Expansion
Group II Fair to Good	ML	Inorganic silts and very fine sands, rock flour, silty or clayey fine sands or clayey silts with slight plasticity.	2000	Medium	High	Low
	CL	Inorganic clays of low to medium plasticity, gravelly clays, sand clays, silty clays, lean clays	2000	Medium	Medium	Medium ¹ to Low
Group III Poor	CH	Inorganic clays of high plasticity, fat clays	2000	Poor	Medium	High ¹
	MH	Inorganic silts, micaceous or distomaceous fine sandy or silty soils, elastic silts.	2000	Poor	High	High

Soil Group	Unified Soil Classification System Symbol	Soil Description	Allowable Bearing in Pounds Per Square Foot with Medium Compaction or Stiffness ⁴	Drainage Characteristics ²	Front Heave Potential	Volume Change Potential Expansion
Group IV Unsatisfactory	OL	Organic silts and organic silty clays of low plasticity.	400	Poor	Medium	Medium
	OH	Organic clays of medium to high plasticity, organic silts.	-0-	Unsatisfactory	Medium	High
	P _t	Peat and other highly organic soils.	-0-	Unsatisfactory	Medium	High

¹ Dangerous expansion might occur if these two soil types are dry but subject to future wetting.

² The percolation rate for good drainage is over 4 inches per hour, medium drainage is 2 to 4 inches per hour, and poor is less than 2 inches per hour.

³ Building code allowable bearing values may differ from those tabulated.

⁴ Allowable bearing value may be increased 25 percent for very compact, coarse grained gravelly or sandy soils or very stiff fine-grained clayey or silty soils. Allowable bearing value shall be decreased 25 percent for loose, coarse-grained gravelly or sandy soils, or soft, fine-grained clayey or silty soils. To determine compactness or stiffness to estimate allowable bearing capacity, measure the number of blows required to drive a 2-inch outside diameter, 1.375-inch inside diameter split-barrel sampler 1 foot into the soil by dropping a 140-pound hammer through a distance of 30 inches.

Question: If a drain tile “sock” is used, can I eliminate some or all of the coarse aggregate?

Answer: No, the tile “sock” doesn’t replace any of the coarse aggregates function and therefore, if used, is only an added safe guard against fines clogging the tile weeps. With some types of soils the “sock” actually will hold certain types of

21.17

finer and can cause basement water problems, so it is not recommended to use this type of 'socked' tile within those soil types having those fines.

21.17 Drain Tile Materials and Installation Requirements

A properly functioning drain tile system will lower the water table (seasonal or longer term) to the level of the tile installation in the immediate vicinity of the foundation wall.

This is important not only to achieve a relatively dry basement, but to maintain the structural integrity of the home. A saturated soil is not only heavier than dry soil, but it also has less internal soil friction that normally helps restrain lateral soil flow. Therefore, the potential lateral pressures exhibited by saturated soils are significantly greater than well-drained foundation backfill. Also a well-drained soil is less likely to frost heave when frozen.

The tile, backfill, and discharge systems are designed to maximize drainage and minimize potential siltation and overload of the system. A well-graded gravel bed and porous backfill are important for proper drain system operation. Also, per s. Comm 21.12, the grade around the dwelling should slope away to minimize the need for the drain tile to handle surface water surcharge.

This office has received some complaints about sump pump systems operating continuously. Contrary to the complainants' concerns, this is usually evidence of a properly functioning system. The real problem is that groundwater in the area is at a relatively shallow depth, local soils are porous, or both. This results in a high volume of flow. These are conditions that should have been considered in making the decision where to site the building by the owner and builder.

Such situations normally occur in lowland areas, where water tables are perched above poor drainage strata, where surface drainage is bad, or where soils are very porous (fractured limestone, gravels, some sand) that allow easy lateral soil water movement. Zoning laws and subdivision ordinances more appropriately regulate whether certain parcels of land should be developed and what floor elevation is required given these conditions. However, zoning codes may not further regulate construction of the foundation drainage systems.

Care should be taken not to allow sump discharge to cause erosion which would result in sediment being deposited off site.

Wisconsin Plumbing Code in Comm 82.36(8)&(4) should be referenced in design of sumps and discharge to surface where a storm sewer is not available.

The bleeders do not need to be connected to the interior and exterior drain tiles with connectors – they may be butted to the tiles and have piece of membrane material, such as building felt, placed over the gap to keep foreign material out.

- Question: What is the proper location for drain tile at the footing level or on the footing?
- Answer: Drain tile is to be placed AT the footing level, not setting on the footing, as the code is specific in Comm 21.17(3)(d)5. that the tile must set on 2 inches of coarse aggregate and be covered with at least 12 inches of coarse aggregate.
- Question: The code talks about the placement of drain tile on 2 inches of coarse aggregate and being covered with 12 inches of coarse aggregate; but how much coarse aggregate is to be placed on the side of the tile?
- Answer: As the code states “covered with at least 12 inches of coarse aggregate,” this includes the outside or side exposed to earth of the tile as well as the top. Normally since one side of the tile (connected to the bleeders) is up against the footing, only the top and side needs the 12 inches of cover.

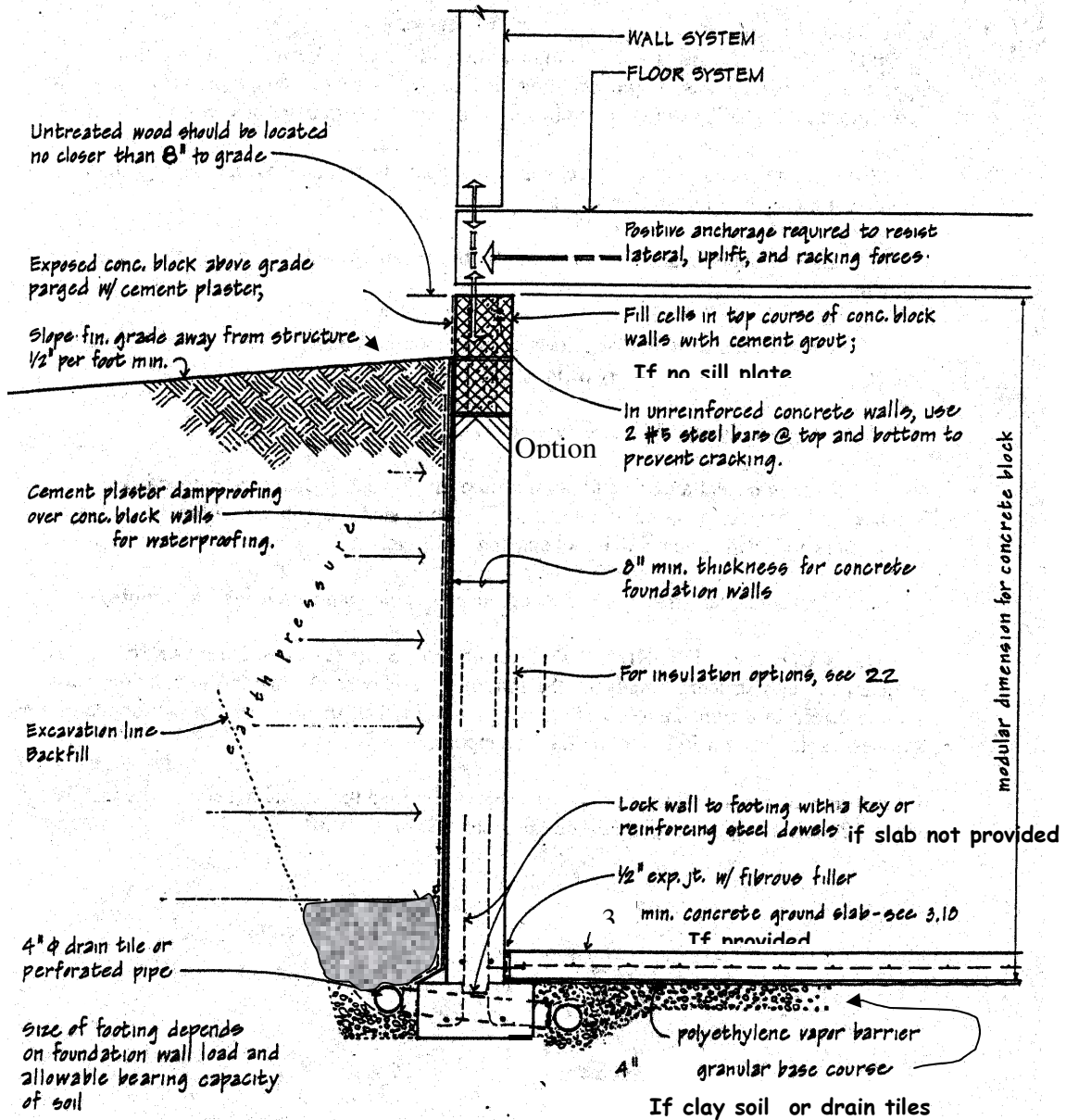

FOUNDATION WALL SECTION

Subchapter V — Foundations

21.18(1) Foundation Wall Lateral Support

Question: Why is lateral restraint required for foundation walls?

Answer: All of the UDC concrete and masonry foundation wall tables are based upon the assumption of lateral support at both the base and top of the walls.

The base of the wall typically is restrained by the floor slab or by the footing with a keyed joint or rebar. The top edge of the foundation wall may be restrained by the first floor through mechanical fastening or ledger blocking. (Ledger blocking alone will not satisfy the dwelling anchorage requirement of s. 21.02(1)).

Section 21.18(1)(c)&(d)2.a. requires that lateral restraint shall be continuous from the wall to the plate to the restraining floor system. This will normally require that solid bridging or blocking be installed between the rim joist and adjacent floor joist that run parallel to the foundation wall to transfer the loads on the wall.

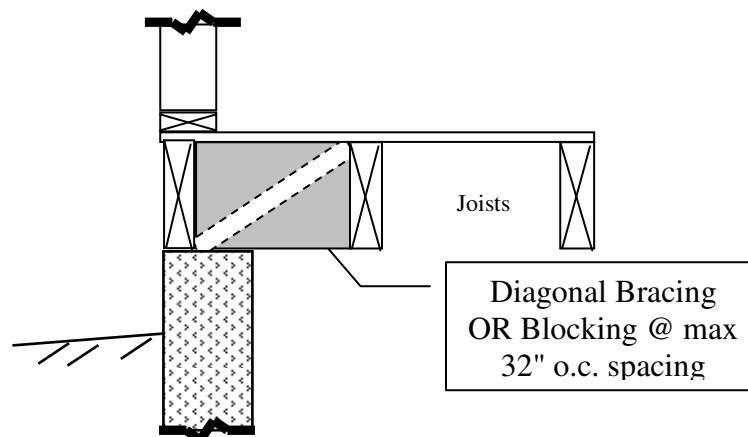

Another method would be to furr the inside of the foundation wall with 2 x 4s or an engineered system secured to the joists and bearing against the foundation wall or foundation wall footing.

A special case arises where the fill around a foundation is uneven, as in a walkout basement. In this case the soil pressure on either side of the house is not balanced, thereby possibly causing lateral racking movement of the foundation and floor system. To resist this, additional lateral support by rigid (plywood sheathed) interior cross walls or by pilasters may be needed.

FOUNDATION LATERAL RESTRAINT

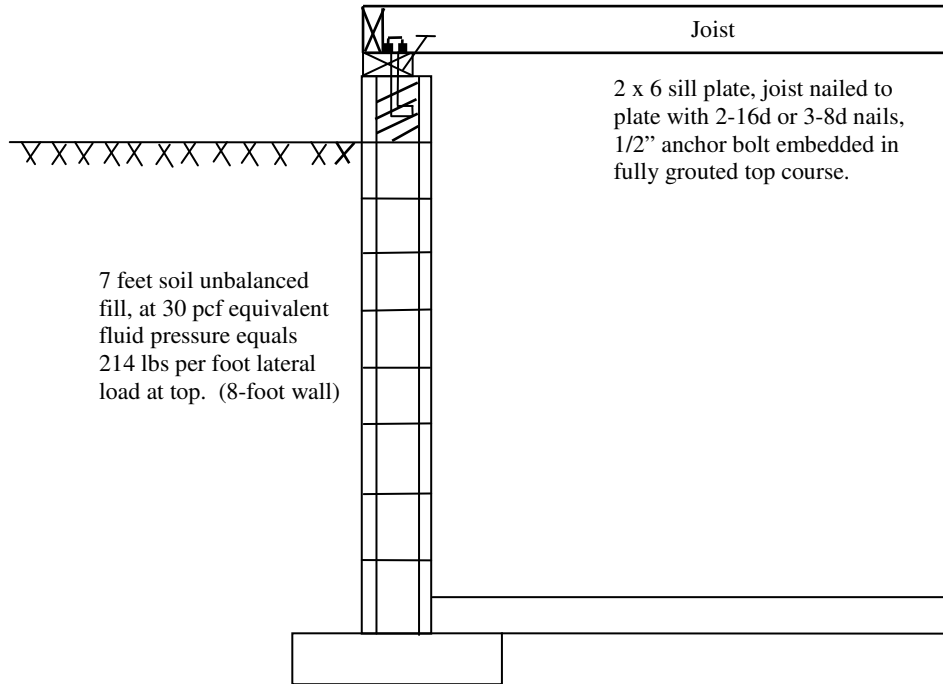

In addition to bolts, other means such as straps or engineered connections may be used to provide lateral restraint to the top of the foundation wall.

21.18(2) Concrete Foundation Walls

Question: Is a 6-inch thick concrete foundation wall acceptable for supporting a 2 x 6 frame wall? The thickness of the frame wall with sheathing, siding, and drywall will exceed the 6-inch foundation wall thickness.

Answer: "In no case shall the thickness of the foundation wall be less than the thickness of the wall it supports." This requirement refers to the width of the structural members of the supported wall. In the wall in question, only the 2 x 6 framing (5.5 inches) are considered structural supporting members, therefore the proposed wall is acceptable.

Question: What does the term nominal wall thickness mean in Table 21.18-B?

Answer: This term was used for when a piece of lumber was used to set the thickness of the wall. That lumber may not have been the full 8 inches in width but had an actual thickness of 7.5 inches at one time. Currently, for softwood lumber of a nominal thickness of 8 inches, the actual thickness can be 7.25 inches. Although it is recommended that the full thickness specified in the table be used, the department will permit a wall to have an actual thickness

less than that specified in the table but it may not be reduced by more than ½ inch.

Question: Are there situations where the department will allow unreinforced concrete supporting walls thinner than specified in Table 21.18-B?

Answer: Yes, the code allows 6-inch unreinforced concrete walls to be used provided the fill is within 12 inches of being evenly balanced on both sides of the wall. The top of any concrete slab and the finish grade is used to determine this measurement, such as in an attached garage situation or slab-on-grade dwelling.

Table 21.18-B was developed to assist in determining the maximum height of unbalanced fill that may be placed against a basement wall. The Uniform Dwelling Code has never dealt directly with the issue of wall thickness where the fill is balanced on both sides. During a past code update cycle, the entry in the table for 6-inch walls was deleted because the American Concrete Institute no longer allows unreinforced foundation walls or exterior basement walls less than 7.5 inches thick. However, section 7.1.6.2 of ACI 318.1-1989 allows bearing walls to be a minimum of 5.5 inches thick. With the fill balanced to within the 12-inch condition imposed above, the wall will be considered a bearing wall rather than a foundation or exterior basement wall. A 12-inch variation will still allow flexibility in grading without necessarily mandating the decay protection of wall structural members. Current ACI 318-2005 section 14.5.3.2 empirical design does not permit less than 7.5" thick basement or foundation walls.

Question: What strength of concrete is a "five-bag mix"?

Answer: The strength of concrete is dependent upon a number of factors including the cement-water ratio involved in the mix. A five-bag mix means that 470 lbs. of cement is used per cubic yard of concrete. Without knowing how much water is also used per cubic yard of concrete, the actual design strength of the concrete cannot be determined. Concrete suppliers should have their design mixes tested prior to field use per the American Concrete Institute (ACI) specifications. (See following section.)

Concrete Foundation Walls (Concrete Quality)

Compressive Strength of Concrete

The average strength of concrete produced must always exceed the specified value of concrete strength (f'_c) that was used in the structural design phase. This is based on probabilistic concepts, and is intended to ensure that adequate strength will be developed in the structure.

Acceptable Practice for Concrete Design

The specified strength of concrete for foundations and footings in one- and two-family dwellings shall be at least 2,500 psi per s. 4.2 of ACI 318.1-89, Plain Concrete Code.

21.18(2)

The height of 3,000 psi concrete foundation walls shall be governed by Table 21.18-B or alternately, for greater or lesser concrete strengths, through engineered design. It is noted that Table 21.18-B assumes the wall has lateral support at both top and bottom.

Proportioning on the Basis of Field Experience

For establishing concrete proportions, emphasis is placed on the use of laboratory trial batches or field experience as the basis for selecting the required water/cement ratio. If an applicable standard deviation for strength tests of the concrete is known, this establishes the target strength level from which the concrete must be proportioned. Otherwise, the proportions must be selected to produce an excess of target strength sufficient to allow for a high degree of variability in the strength tests.

Where the concrete production facility has a record based on at least 30 consecutive strength tests representing similar materials and conditions to those expected, the strength used as the basis for selecting proportions shall exceed the required specified strength of concrete (f'_c) by at least:

TABLE A. REQUIRED OVERDESIGN

Standard Deviation (psi)	Required Average (psi)
Under 300	$f'_c + 400$
300 - 400	$f'_c + 550$
400 - 500	$f'_c + 700$
500 - 600	$f'_c + 900$
Over 600	$f'_c + 1200$
Unknown	$f'_c + 1200$

The indicated average strength levels are intended to reduce the probability of concrete strength being questioned on any of the following usual bases: (1) too many tests below specified f'_c ; (2) strength averaging below specified f' for an appreciable period (three consecutive tests); or (3) an individual test being disturbingly low (more than 500 psi below specified f'_c).

Proportioning on Basis of Acceptable Practice

If test data is not available, the following water/cement weight ratio may be used to determine acceptable concrete strength.

3000 PSI concrete use 0.58 water/cement ratio

The following tables give guidelines for proportioning a mix of 1 cubic yard to develop acceptable strength levels. Recommended slump for footings, foundation and slabs is between 1 and 3 inches.

TABLE C APPROXIMATE MIX FOR SLUMP OF 1-2 INCHES

Size <u>Aggregate</u>	Water <u>Lbs.</u>	<u>Gallons</u>	<u>3000 PSI</u>		Percent* Volume of Coarse <u>Aggregate</u>
			LB. of <u>Cement</u>	94# <u>Bags</u>	
1/2"	335	40	578	6.2	50-60
1"	300	36	517	5.5	64-72
1 1/2"	275	33	474	5.0	68-76
2"	260	31	448	4.8	71-79

TABLE D APPROXIMATE MIX FOR SLUMP OF 3-4 INCHES

Size <u>Aggregate</u>	Water <u>Lbs.</u>	<u>Gallons</u>	<u>3000 PSI</u>		Percent* Volume of Coarse <u>Aggregate</u>
			LB. of <u>Cement</u>	94# <u>Bags</u>	
1/2"	365	44	629	6.7	50-60
1"	325	39	560	6.0	64-72
1 1/2"	300	36	517	5.5	68-76
2"	285	34	508	5.4	71-79

*Percent of coarse aggregate will vary with different fineness moduli of sand.

21.18(2) & (3)(a) Dampproofing

Question: Could you clarify the UDC requirements for waterproofing of poured concrete foundation walls?

Answer: This section only specifically addresses dampproofing of masonry foundation walls. Section Comm 20.24(2) adopts American Concrete Institute's Standard ACI 318-05 for reinforced and plain concrete. This standard does not mention waterproofing requirements. In summary, there are no requirements for waterproofing of poured concrete walls in new one- and two-family dwelling construction.

Question: Does a masonry foundation wall have to be dampproofed before the insulation is applied?

Answer: Yes, this section requires dampproofing of masonry foundation walls of basements. The exterior applied insulation may then be installed. Alternate systems do exist that use a layer of insulation. These need a Wisconsin Building Material Approval or show equivalency with the code's dampproofing requirements.

21.18(3) Masonry Foundation Walls

21.205

In addition to Tables 21.18-B, C, D, or E, designers may use two alternative methods of designing masonry walls.

1. Builder may design a reinforced wall design using structural analysis per s. Comm 21.18(2) and s. Comm 21.02(3)(e) "Concrete Masonry Handbook" or other accepted engineering standard.
2. Builder may design using IBC 2109 of the Commercial Building Code as an engineering standard. This "Empirical Method of Design" could be used as a structural design aid per s. Comm 21.18(2).

21.18(4) Wood Foundations

A copy of the Permanent Wood Foundation Design Specification, ANSI/AF&PA PWF-2007 may be obtained from the:

American Forest & Paper Association
1111 19th Street, NW Suite 800
Washington, DC 20036
(202) 463-2700 · info@afandpa.org

The UDC also permits the use of the Permanent Wood Foundations Design and Construction Guide published by Southern Forest Products Association through the Southern Pine Council. You may view and download a copy of this guide for free by accessing their website www.southernpine.com.

Subchapter VI — Floors

21.203 Garage Floors

Question: Can the garage floor be at the same elevation as the finished floor of the dwelling or is a step or landing required in the garage at a door between the two?

Answer: The code doesn't require an elevation change between the garage floor and the dwelling floor, only that the garage floor slope to the main exterior opening or floor drain. Some local ordinances required a step, but no national building codes have required a step there. In fact, builders who are concerned with handicap accessibility are promoting the same height floor level for garages.

Question: What is the minimum pitch of the garage floor?

Answer: The code is silent on this and doesn't prescribe the degree of pitch, only that it must have a slope to provide drainage. A suggested rule of thumb for concrete flat work is 1/8 inch drop per foot of run.

21.205 Wood Floors in Contact with the Ground

Such floors would also have to comply with Comm 21.10(1)to(5).

21.22(1) Floor Joist Design

Question: Does the deflection of floor joists have to be limited to the $L/360$ as shown in the upper left corner of Table J-1 found in the code appendix.

Answer: There is no requirement in ch. Comm 21 stating what the maximum deflection of structural members must be. Deflection would, therefore, be controlled indirectly through accepted engineering practice. Also, there is no rule in Ch. Comm 21 which specifically states that deflection in Table J-1 is part of the rule. All appendix tables are deemed to meet the minimum standards.

22.22(1) Floor Joists and Sill Plates

Question: A wood floor joist system is resting on a sill plate which in turn rests on a hollow concrete masonry foundation. Does the top course of masonry need to have all cores and joints filled with mortar?

Answer: Per s. Comm 21.22(1)(d), the cores of the blocks need not be filled as long as a sill plate is as wide as the block itself is used. If a sill plate is smaller than the width of the block or if a sill plate is not used, then all the cores must be filled.

21.22(3) Steel Beams

Question: Please explain the terminology for steel beams in Table 21.22-A1.

Answer: A-36 steel refers to the strength of the steel. It has an allowable tensile yield strength of 36,000 pounds per square inch. Most beams are now A-50 steel.

The designations W and M refer to the standard cross-sectional shapes of steel beams. The term I beam is no longer used, but does describe the general shape of these beams. The major differentiating characteristics of a beam are its top and bottom flanges which are horizontal and the vertical web which separates the flanges. The specific descriptions are:

"W" - The top and bottom flanges are parallel to each other. Previously called a wide flange beam in some cases.

"M" - Cannot be classified as a W or S shape. Sometimes referred to as a junior I beam previously.

It is always best to get the actual shape designation from the suppliers. The two numbers after the shape designation (W, M) provide (1) the overall depth of the beam section and (2) the weight of the beam itself in pounds per lineal foot.

So a beam designated as a W 8 x 15 has a W shape with relatively wide flanges, a depth of 8 inches and weighs 15 pounds per lineal foot.

21.22(3)

Question: Table 21.22-A1 gives sizes for beams when conventional framing is used. Table 21.22-A2 gives sizes of wood beams when truss roofs are used. Are there any tables that can be used for steel girders and beams when using truss roofs?

Answer: The correct size of a steel beam can be obtained through use of the Steel Construction Manual published by the American Institute of Steel Construction, Inc. This is the same organization that publishes the standard as adopted in s. Comm 20.24(2). This manual contains tables covering different sizes and shapes of steel beams and specifies the maximum load the beam can carry for a certain span. Table A of the following commentary section (21.22(3)) can be used to determine the actual load on the beam. In order to determine the total load on the beam, the actual load on the beam in pounds per lineal inch as calculated by Table A must be multiplied by the number of inches between the supports. The table found in Chapter 2 of the Steel Construction Manual can then be used by selecting a beam and then comparing the actual load on the beam calculated with the maximum allowable load of the beam. There are also structural software programs that may be used.

21.22(3) Wood Girder and Beam Design

The beam design tables as given in the Uniform Dwelling Code may be used for the design or analysis of simple span timber beams and headers with uniformly distributed loads.

The structural analysis for simple beams and headers are based on the following formulas:

BENDING

$$M = \frac{w(l)^2}{8}, S = \frac{M}{F_b}$$

HORIZONTAL SHEAR

$$R_v = \frac{w(l)}{2}, F_v = \frac{3(R_v)}{2(b)(d)}$$

$$\text{DEFLECTION "Delta"} = \frac{5(w)(l)^4}{384(E)(I)} \quad (\text{See Note D})$$

- w = uniform load per length in inches (See Note A)
- l = length of beam between supporting members in inches
- b = width of rectangular member (actual not nominal) in inches
- d = depth of rectangular member (actual not nominal) in inches
- S = section modulus of lumber (See Note B)
- M = bending moment in inch-pounds
- E = modulus of elasticity of lumber (See Note C) in psi
- I = moment of inertia (See Note B) in (inches)⁴
- F = allowable unit stress for extreme fiber (See Note C) in psi

F_v = allowable unit horizontal shear (See Note C) in psi
 R_v = vertical reaction in pounds
 = deflection in inches

NOTE A - the uniform load per inch on a beam is calculated from the live loads (LL) and dead loads (DL) in pounds per square foot (s. Comm 21.02) and length in inches of supported joists (J). The formula is: $w = (DL + LL) (J) / 144$

If more than one level is supported by beam or header, add the loads contributed by each ceiling, floor, and roof system supported to obtain the total uniform load per length on the beam. (See following diagram.)

NOTE B - The National Design Specification for Wood Construction, Appendix M gives the value for (S) and (I) for structural lumber. If built up beams and headers are used, the (S) and (I) for each member can be added together if of the same depth for rectangular members:

$$S = \frac{(b)(d)^2}{6} \quad \& \quad I = \frac{(b)(d)^3}{12}$$

NOTE C - F_b , F_v and E for various wood species can be obtained from Table 4A in the Design Value for Wood Construction Supplement to the National Design Specification for Wood Construction. The values for F_b , F_v & E (allowable) for the wood species must exceed the calculated f_b , f_v & E values (actual).

NOTE D - Deflection "Delta" should be limited to $(l)/240$ to reduce plaster cracking, objectionable springiness, and stresses on mechanical systems.

Tributary Areas

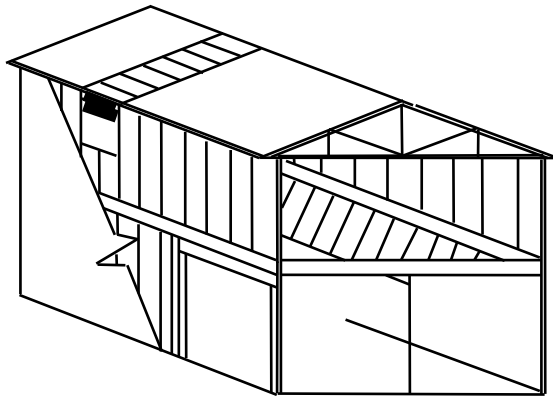

Supported joist length equals 1/2 the sum of the joist plus 1/2 the required bearing area called for in the code or truss spans on both sides of beam or header

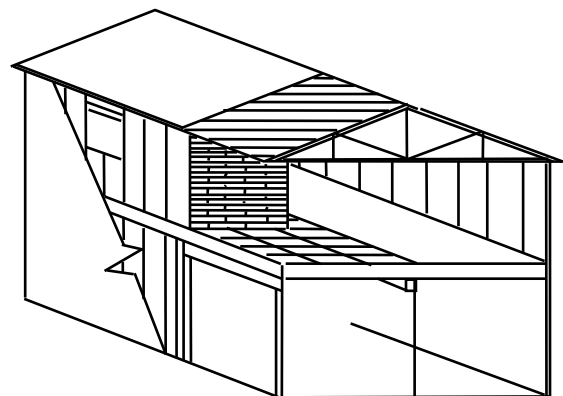

When the beam or header supports more than one structural system, the loads of each system are added.

The following table may be used to size beams or headers. Table A provides the actual loads per inch on the member for various loading situations.

TABLE A Designed to give load (w) on a beam or header for various roof, ceiling and floor systems in pounds per lineal inch. Includes dead and live loads. If multiple loads are supported by the beam or header, then add the loads together from the applicable columns.

Supported Member Length in Feet*	(w)** Roof Zone 1	(w)** Roof Zone 2	(w) Ceiling Truss No Storage	(w) Ceiling Joist No Storage	(w) Ceiling Joist With Storage	(w) Floor: Per System
4	15	13	3	7	10	17
5	19	15	4	9	13	21
6	22	18	5	10	15	25
7	26	21	6	12	18	30
8	31	25	7	14	21	35
9	34	27	8	16	24	39
10	38	30	9	18	26	43
11	41	34	10	19	29	47
12	44	37	11	21	31	51
13	49	40	12	23	33	56
14	53	42	13	24	37	60
15	56	45	14	26	39	64
16	60	48	15	28	42	69
17	64	51	16	29	44	73
18	66	53	17	31	46	76

*See previous page for diagrams. Note that you may need to use different lines of this table for a beam or header that supports multiple systems of different supported member length.

**When there is a roof overhang, its length must be added to the supported member length.

BEAM OR HEADER ACTUAL LOAD = ROOF (w) + CEILING (w) + FLOOR (w)

Bearing of floor systems beams & girders [per Comm 21.22(4)(a)2.] or engineered wood products [per Comm 21.22(4)(b)] should be considered to have the load path [from Comm 21.02(1) requirement] followed beyond just the bearing point sizing for adequate load transfer, thus such beams may require additional wall studs directly below them all the way to the foundation below. If such supports have a header in them, typically separate structural analysis must be provided to properly size this header and those supporting jamb columns.

21.22(4) Floor Joist Tails

Question: Why can't the tail ends of joists overlap by more than the depth of a floor joist?

Answer: The reason for the requirement is to prevent potential subfloor uplift from the tail end reaction to the deflection of the joist span. This could be more of a problem at the center beam of a house in which the clear span roof trusses are used and there is no bearing wall resting on the floor joist tail ends.

Question: Can wood shims be used under a steel beam or under a steel column for minor dimensional adjustments? What about pressure treated lumber?

Answer: Maybe, but not likely, since the shim material used would need a compressive strength equal to or greater than the loads imposed by the typically highly loaded steel members. If structural calculations are lacking on this point, then steel shims would be required.

Holes & Notches in Sawn Joists and Rafters (D = Actual Member Depth)			
Member Size	Maximum Hole Diameter or Notch Length = D/3	Maximum Edge-Hole Diameter or Notch Depth (except at ends) = D/6	Maximum End Notch = D/4
2x6	1-3/4"	7/8"	1-3/8"
2x8	2-3/8"	1-1/4"	1-7/8"
2x10	3"	1-1/2"	2-3/8"
2x12	3-3/4"	1-7/8"	2-7/8"

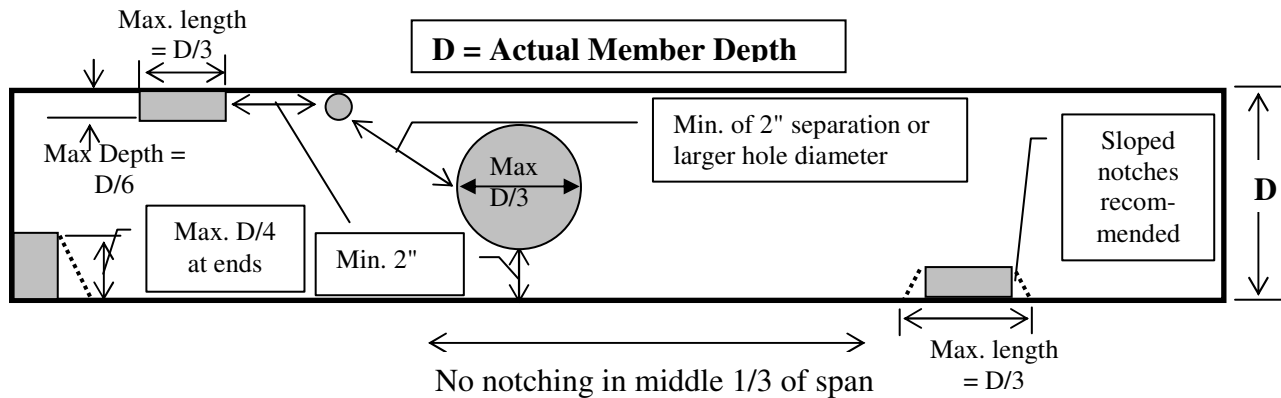

21.22(6)

21.22(6) Lookout Joist Cantilevers

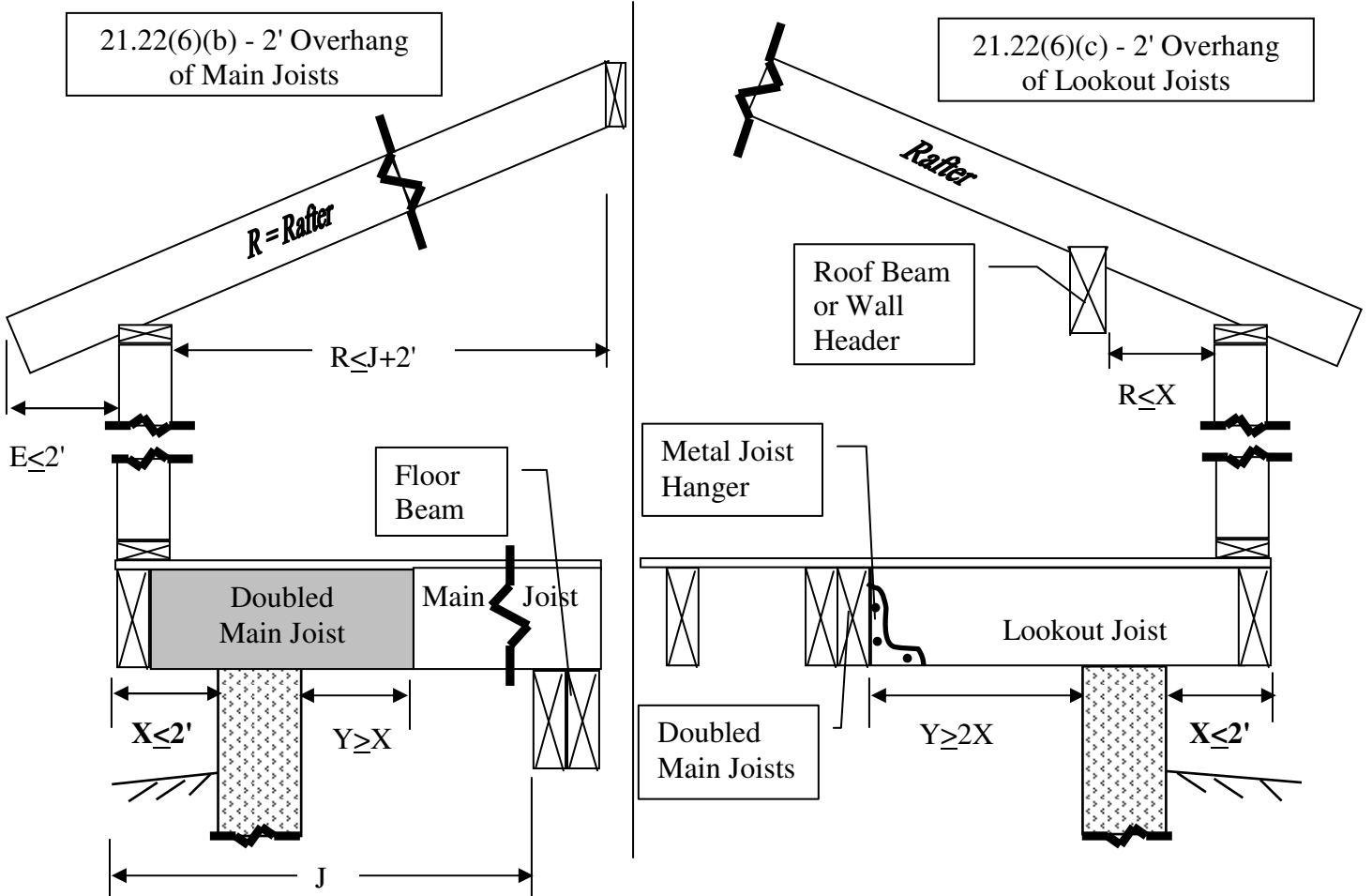

21.22(3) Beam Lateral Restraint

Deeper than 11.25" wood beams at supporting columns shall be provided with lateral restraint by means of a saddle or other approved connection. A saddle supports the beam on the bottom, but also allows through-connection of fasteners into the side of the beam.

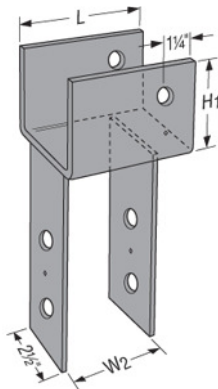

21.22(6) Deck Cantilevers

Question: This section allows a 2-foot cantilever that supports the wall and roof above without the need for calculations. Again, without project specific calculations being required, how far may a deck be cantilevered when it only supports its own floor load?

Answer: In the case of the code allowed 2-foot cantilever, the floor assembly is supporting its own known uniform floor load and a point load from the roof system of an unknown span. Therefore it is very conservative. In the proposed case of a cantilevered deck supporting only its own floor load, the loads are all known, therefore a more liberal treatment is possible. So theoretically, the cantilever could be one-half of the simple beam span. This would also parallel the requirement of s. Comm 21.22(6)(b) that the cantilever be anchored back two times the overhang. However, the owner may be unhappy with the deflection at the end of the deck, since for a given span, the deflection for a cantilever is about ten times that of a simple span.

Besides the above analysis, the designer should evaluate the need for any uplift restraint on the backspan at the most critical loading where the cantilever has full live plus dead loads, while the backspan is under dead load only.

The deflection, non-uniform loading and uplift concerns, should be addressed by the designer. Also, the designer must confirm the assumption that the backspan joist is adequate for the simple span loading case before using the above formula to determine the cantilever length.

21.22(7) Joists Bearing Over Window Openings

In the absence of a wall header, the requirements of Comm 21.22(7) apply to floor joists that end above a window or other wall opening. This is typically the case for basement windows. Therefore, either framing anchors or a ledge strip, including a sill plate, is required for proper bearing for any joists over 8 feet long.

21.24 Exterior Covering

Question: Must the siding or finished surface material be in place before insulation can be installed?

Answer: No, so long as it is “protected” from the elements which could cause excessive moisture in the finished walls. This “protection” could be any of the materials above. You should note that most building paper is listed by the manufacturer to not be directly exposed to weathering (sunlight & rain) for extended periods, unless it will be replaced before finish siding materials are installed over it. Also note that this requirement does include gable & dormer walls, not just walls which are part of the building thermal envelope [for which building paper may be used to meet infiltration resistance requirements of Comm 22].

21.24 (4) Water Resistive Barrier (Drainage Plane)

21.25(3)

Specific standards for water-resistive barrier materials are now found in the code. These include material compatibility, performance and application requirements, as well as minimum protection or flashing of most penetrations of the barrier materials.

21.25 Wood Frame Walls

Question: Based on Table 21.25-A, if I have an exterior gable end-wall with a cathedral ceiling that is greater than the stud height allowed, do I have any options other than cutting the studs and installing double top plates?

Answer: Yes, if the allowable height is exceeded, there are three ways of handling this condition:

1. If the maximum allowed stud length is 10 feet, continuous 2" full-depth solid wood blocking could be installed throughout the wall between all studs at the mid-point of the wall height (but in no case exceeding the 10' limitation).
2. The second option would be to install solid wood sheathing material on both the exterior and the interior of this stud wall, covering the entire wall area (under the interior wall finish).
3. Use engineered lumber

Table 21.25-A allows some non-bearing stud walls with heights exceeding the 10' maximum that was previously allowed without structural analysis. Per the table footnote, these non-bearing wall heights are for interior walls only.

21.25(3) Wall Opening Framing

Question What are some examples of acceptable headers for openings in exterior walls?

Answer Header sizes shown in Tables 21.25-B, C, & D for dimension lumber are acceptable typical headers. For headers exceeding the spans given in Tables 21.25-B, C, and D, see s. 21.22(3) of this commentary for design information.

Comm 21.25(3)(b) prescribes header support minimum standards. The following diagrams are intended to clarify the text. Remember that the "span" is the clear span plus $\frac{1}{2}$ the required bearing area of the header at each end.

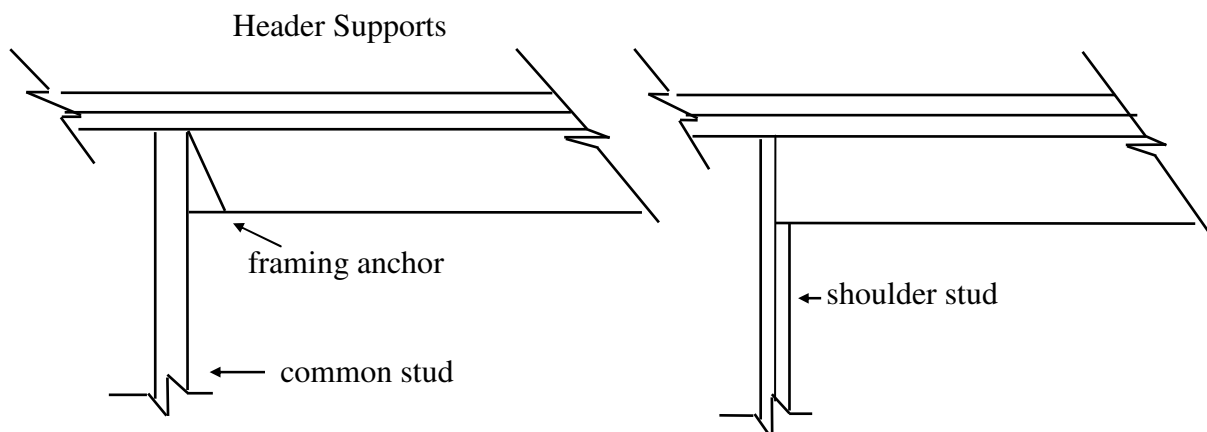

Either option for up to a 3-foot span.

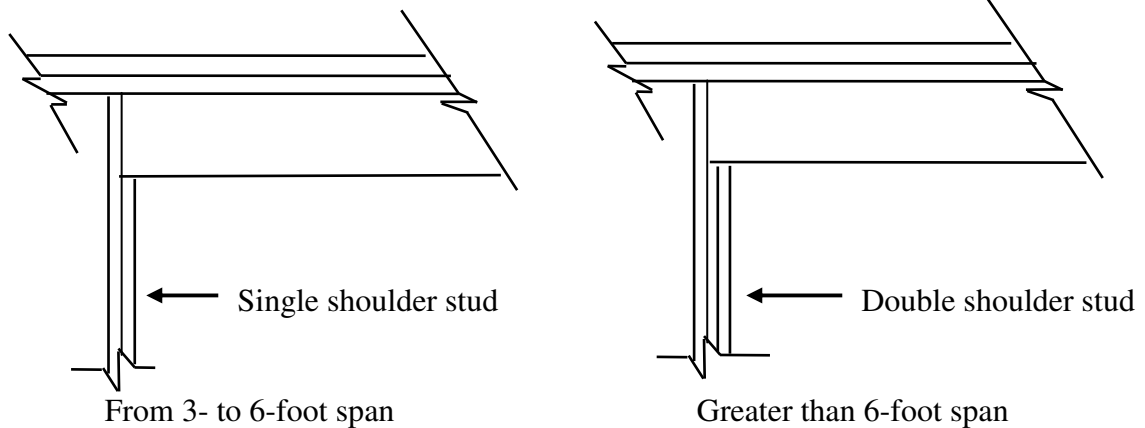

21.25(6) Telescoping Columns

Question: Are telescoping or expandable jacks or columns allowed in the construction of one- and two-family dwellings?

Answer: The use of the telescoping jack post (adjustable height columns) to support beams is not prohibited by the UDC provided they are capable of supporting the imposed loading per Comm 21.25(6)(c)1. The installation shall comply with the manufacturer's installation instructions for spacing, load capacity, maximum height adjustment, beam or footing anchorage and proper method to secure the adjustment device while in service. The adjustable jack should be stamped or bear a sticker which indicates its allowable load. They must be secured at both the top and bottom of the column the same as any other column. Caution should be used on the limitations of screw adjustment permitted for a particular load and even which end is up must follow listing.

Question: What are foundation cripple walls?

Answer: Rules under Comm 21.25(7) were added in 2009 to address the hinge-action caused by placing a wood-framed wall above a partial-height foundation wall of typically masonry or concrete exterior of ground floor or walk-out basement.

21.25(8)

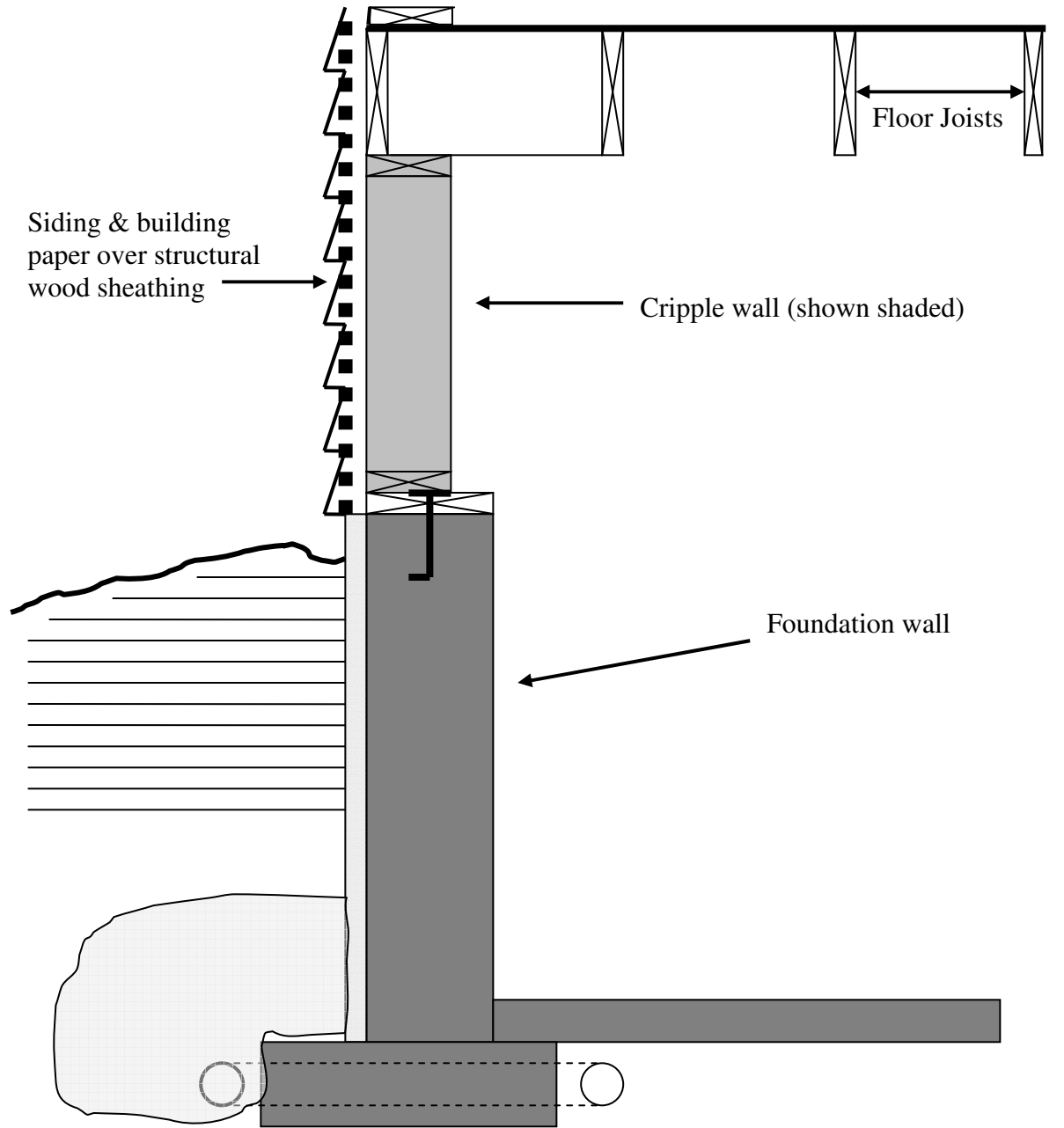

21.25(8) & (9) Wall Bracing

Since the first edition of the Uniform Dwelling Code (UDC) that became effective June 1, 1980, the UDC has required construction that resists lateral wind loads of 20 pounds per square foot of external wall area. This change in the rules on wall bracing incorporate more design and construction specifications in an effort to assure the long-standing performance requirement is met. The additional specifications are based on those contained in the 2006 edition and 2007 supplement of the International Residential Code, developed by the International Code Council.

There are a couple of terms a person will need to become familiar with whether using the interminante bracing method of Comm 21.25 (8), alternate bracing method of Comm 21.25 (9)(b) or the continuous sheathing method of 21.25 (9) (c):

Braced Wall Line: A braced wall line (BWL) consists of wall segments that are off-set no more than 4' from the BWL. Within that braced wall line are braced wall panel(s) that provide resistance to wind loads. The spacing of a BWL shall not exceed 35', or 50' meeting certain additional conditions. [See Comm 21.25 (8)(e) and Fig. 21.25-A]

Braced Wall Panel: A braced wall panel (BWP) is an individual bracing component that is installed within a braced wall line. Examples of types of BWP are let-in bracing, wood boards, wood structural panels, structural fiberboard, and gypsum board [See Comm 21.25 (8) (b)]. The BWP, unless otherwise specified in the code, shall begin no more than 12.5 feet from each end and shall be located every 25 feet on center.

Question: May the latest wall bracing provisions, s. R602.10, set forth in the 2009 edition of the International Residential Code (IRC) be used to meet the wall bracing provisions this code?

Answer: Yes. When using the UDC provision or the 2009 IRC provision, whichever one is used, it shall be used in its entirety. The provision of each may not be mixed and matched. Once the 2009 IRC wall bracing provisions are available for reprint, they will be reprinted in the UDC appendix. For the time being the 2009 IRC can be viewed on the ICC website www.iccsafe.org. Select the ICC Store tab and click on the dropdown box eCodes.

Question: Comm. 21.25(8)(b)6. requires gypsum boards used as braced wall panels to be fastened at panel edges by nails specified in the fastener table in the appendix spaced no more than 7 inches on center while the fastener table itself specifies a spacing of 4 in. on the edges and 8 inches at intermediate supports. Which one controls?

Answer: The fastener spacing specified in the table is for gypsum sheathing used on the exterior of the building. Gypsum boards used as bracing panels on interior walls may have fasteners spaced 7 inches on center.

Question: May four (4) foot long braced wall panels be used as a substitute where wood and metal let-in bracing is permitted by Table 21.25-G?

Answer: Yes. Let-in bracing may not, though, be used as a substitute for braced wall panels where required by Table 21.25-G.

21.25(8)

Question: May I use wood structural panels less than 4 ft. in length in a braced wall line and comply with the intermittent braced wall provisions of the Comm 21.25 (8)?

Answer: Yes. As long as the length used meets Table 21.25-G and the “effective” length used to determine panel bracing percentage is as specified in the same. [See example calculation and figure below.]

Example: [Effective braced wall panel length = 36” X 2 = 72”] > [0.16 X 35’ or 67.2” from Table 21.25-H] OK.

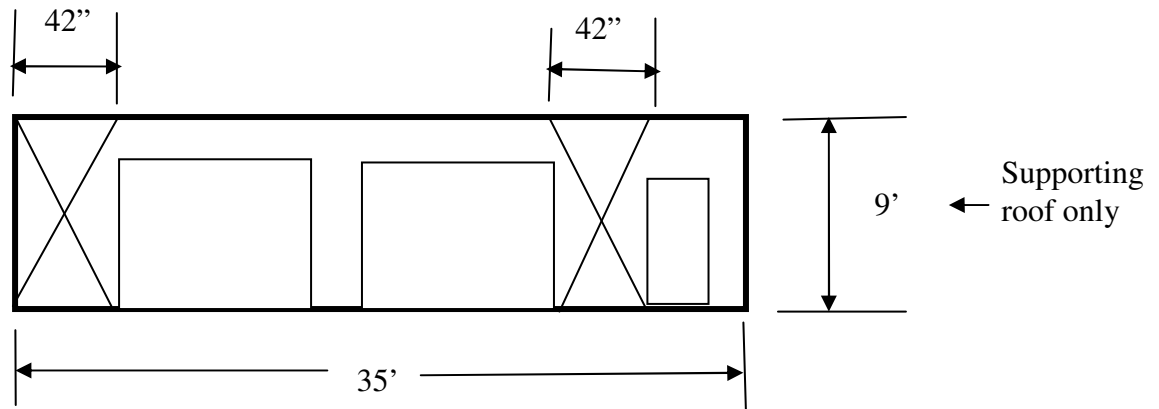

Question: Section Comm 21.25(8) (e)2. refers to Table 21.25-G when determining the “adjusted” percent wall bracing. Is that the right table to reference?

Answer: No. The table that should be referenced is Table 21.25-H.

Question: What is the maximum wall height permitted when using the “prescriptive” wall bracing methods of Comm 21.25 (8) & (9)?

Answer: 12 feet. See Table 21.25-H, footnote 4, and Table 2.25-I where 12 foot height walls would be permitted. Code compliance for those walls greater than those heights specified in these sections will need to be designed and constructed in accordance with accepted engineering practice.

Question: If my braced wall line spacing is more than 35 feet and is less than, or equal to, 50 ft. may I use wood or metal let-in bracing in those braced wall lines that are spaced more than 35 ft. apart?

Answer: No. Braced wall lines that are more than 35 ft. apart must have the required length of braced wall panels specified in Table 21.25-H increased by a factor of the braced wall line spacing divided by 35. Let-in bracing does not provide an equivalent amount of wind resistance as compared to the added sheathing required by this section.

Braced wall lines spaced more than 35 ft. apart and let-in bracing

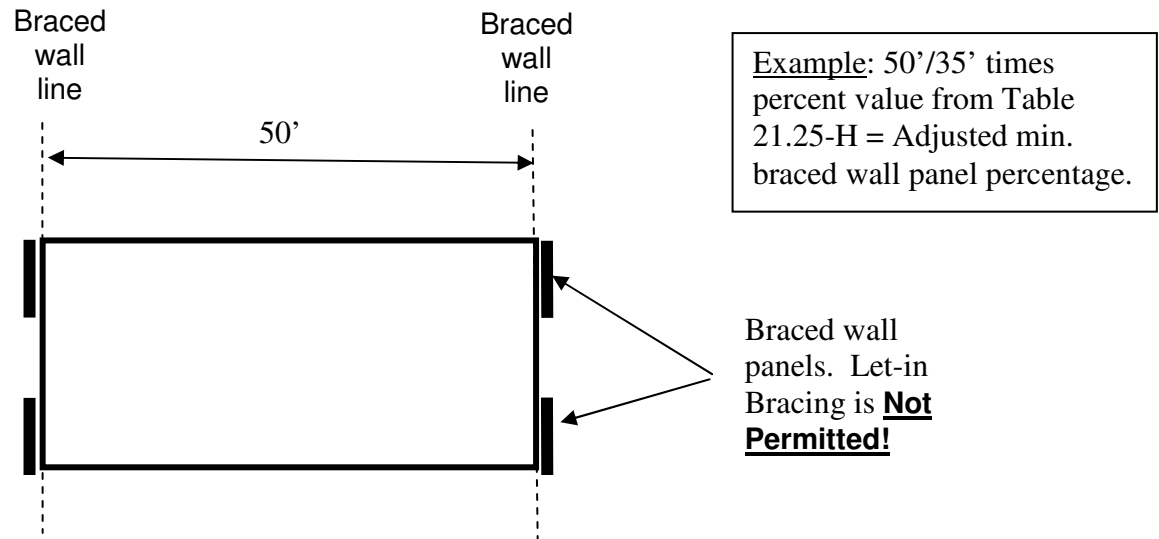

Question: The last sentence in Footnote 5 of Table 21.25-H refers to Table 21.25-J. Is that the right table reference?

Answer: No. The table that should be referenced is Table 21.25-K.

Question: If I have a walk-out basement with a full-height wood frame exterior wall on one side and the rest of the floor level is below grade, do I need an interior braced wall line if the length of the wall is greater than 35 feet?

Answer: No. The braced wall lines spaced at 35 feet are there to provide resistance to wind loads. Since the wall is braced at the top by the floor system and the load is transferred through the floor system to the below grade foundation wall on the opposite side of the ground floor, the lateral resistance to wind for the wall is provided. The exposed exterior walls, though, would still have to meet the wall bracing provisions of Comm 21.25 (8) and/or (9).

21.25(8)

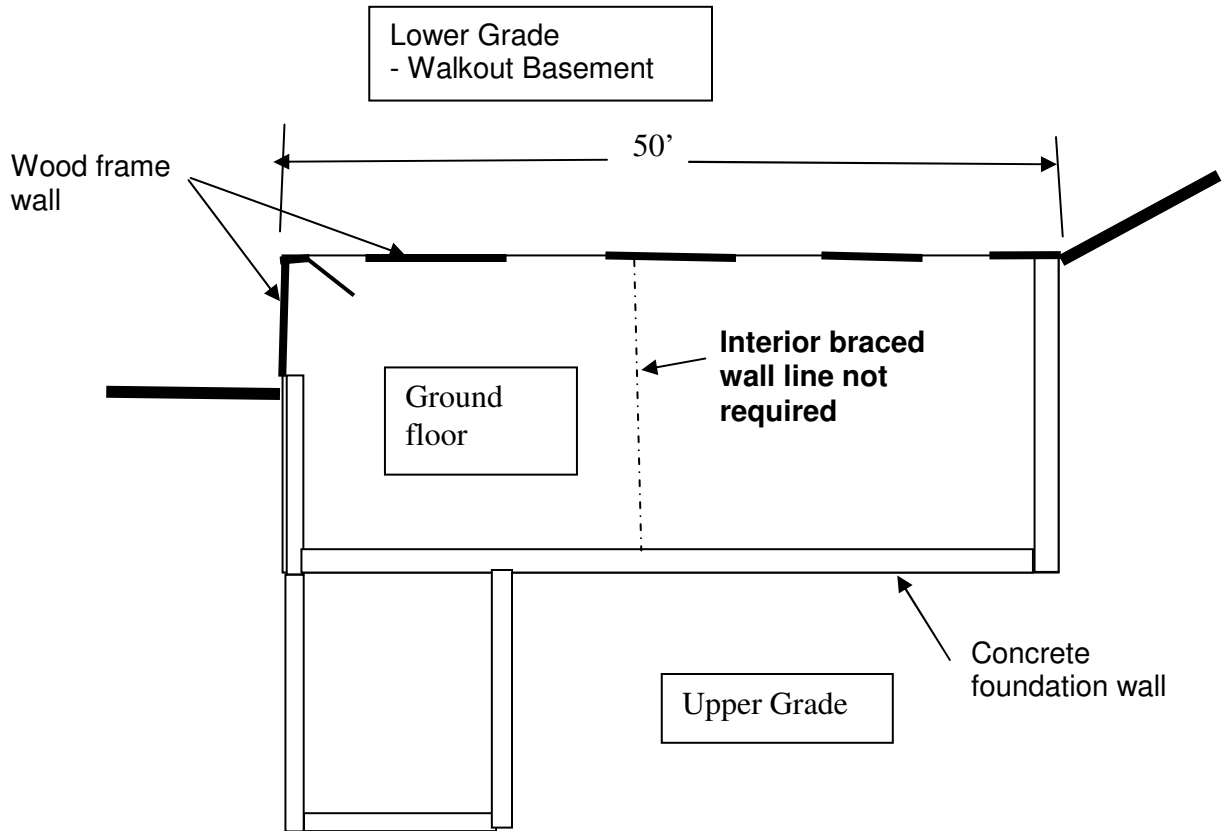

Question: Must a braced wall line with 4' offsets be in line with an actual building wall line as shown in Fig. 21.25-C?

Answer: No. A braced wall line can be located within actual building wall lines as long as the physical building wall lines are not offset by more than 4 ft. (See Fig. below). This method of determining the braced wall line is consistent with the wall bracing provisions of the 2009 International Residential Code which is an approved engineering analysis as set forth in Comm. 21.25(8)(1), footnote.

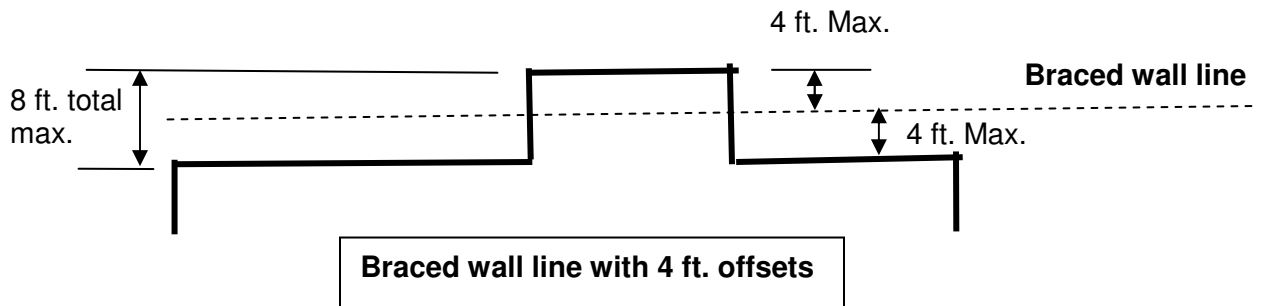

Question: If I fully sheath my homes have I automatically satisfied the requirements of the wall bracing provisions of the UDC?

Answer: No. The plans will have to clearly show the location and design detail of the braced wall panels, the location and details of required interior braced wall lines and their panel(s), location and details of required corner and 2-foot end-wall return(s), location and details of required tie-downs, etc. as specified in Comm 21.15 (8) and (9)(c).

Even if the home is fully sheathed, it is suggested that the builder/designer first determine if the intermittent braced wall panel method of Comm. 21.25 (8) can be used. This would eliminate the need for the 2-foot end-wall returns, special corner construction, the possible need for tie-downs, etc. If you can not comply with the intermittent wall bracing provisions, then take a look at using the continuously sheathed wall bracing method. If there are still wall segments that are too narrow when applying the continuously sheathed method, a person can look at using Fig. 21.25-K, then 21.25-E and, finally, going to a proprietary wall bracing system.

Question: If I fully sheath my homes, do all of my panels have to have blocking at all the joints?

Answer: No. Only the required braced wall panels need to be blocked. This would also exclude the 2-foot end-wall returns. [See Comm. 21.25 (8)(h) 1. and 2.]

Question: If I use the continuously sheathed method of Comm 21.25 (9) (c) do also need to space braced wall panels no more than 25 on center?

Answer: Yes. Comm 21.25 (8) (d) is the general section that also applies to the provisions of Comm 21.25 (9) (c). Comm 21.25 (9) (c) permits you to use narrower wall bracing panels in a braced wall line.

Question: When determining the braced wall panel length requirements using Table 21.25-J may I use the 4:1 ration for full-height sheathed wall segments on either side of garage openings?

Answer: Yes. Footnote 2 of the table permits you to do this. This exception, though, is limited to a garage that supports a roof only. It may not have occupied space above it such as a bonus room, attic storage, second floor.

Question: Fig. 21.25-G, (c) refers of sub. (9) (c) 6. for garage door corner details. Is that the right section to reference?

Answer: No. The section that should be referenced is sub. (9) (c) 5.

Question: Fig. 21.25-G specifies that 8d nails be used while the fastener table in the appendix permits 6d nails for wall bracing panels with a thickness of 5/16"

21.25(8)

to 1/2". Is the 6d nail permitted in these corners when use sheathing in that thickness range?



Answer: No. The most restrictive applies. 8d nails shall provided in those areas shown in figure 21.25-G.

Wall Bracing Examples:



Building #1
One-Story

Front Elevation

-  Continuously- sheathed per s. Comm 21.25(9)(c)5.. Fig. 21.25-K.
-  Four Feet of Wood Structural Panel Sheathing or Diagonal
-  Four Feet of Gypsum Wallboard Applied to Both Sides of Wall or Diagonal Bracing.

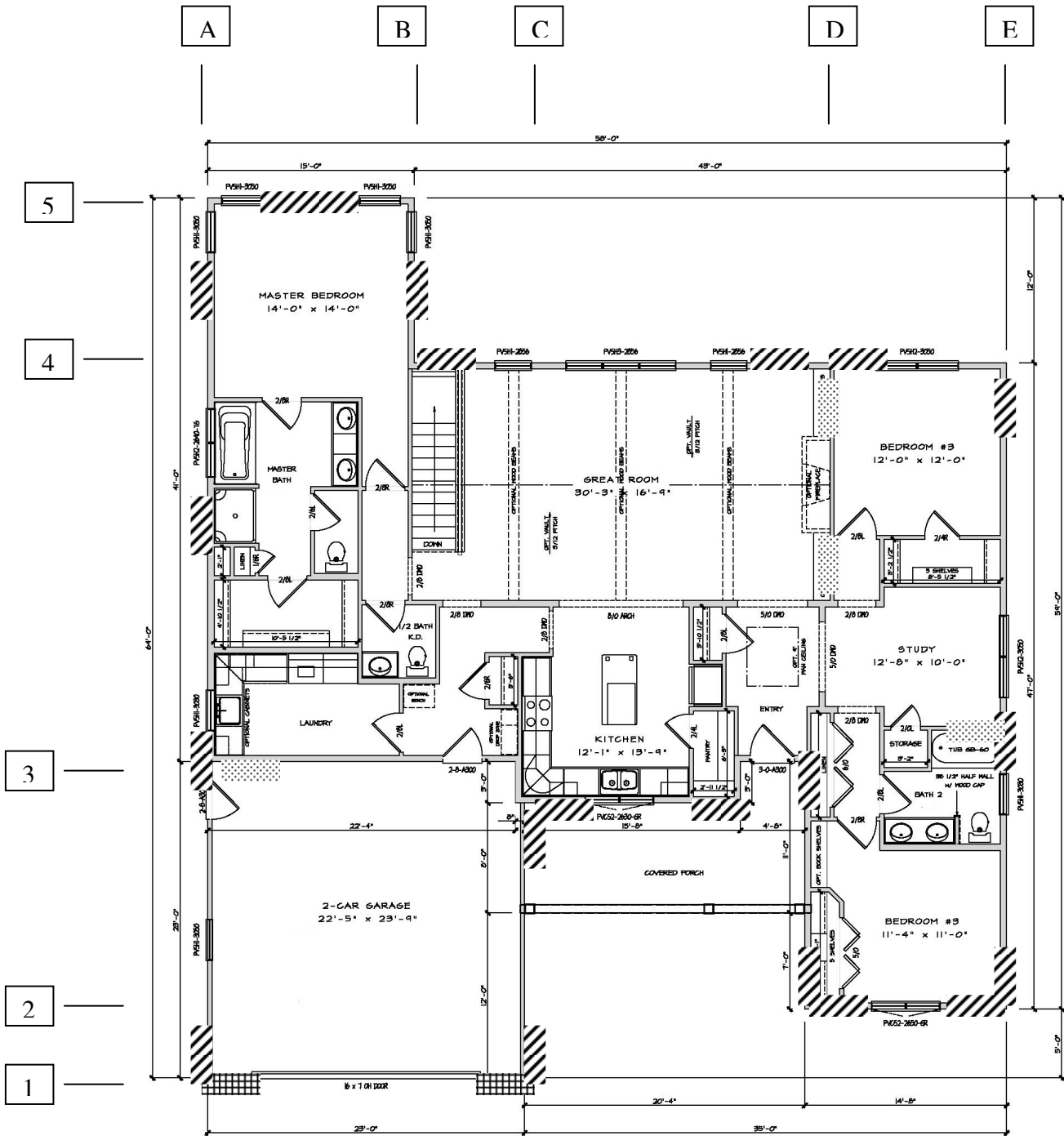

Building #1
One-Story

First Floor

2009-21-69

Steps used to determine wall bracing for Bldg. # 1

[Note: The plans and selected bracing solutions were presented at the winter 2009 building inspector association sponsored UDC training sessions. Alternative wall bracing solutions have been provided in this training module.]

1. Find braced wall lines in exterior walls using north-south and east-west grid line pattern. Braced wall lines may include walls that are offset no more than 4 ft. [Comm 21.25(8)(e)]
2. Check the width of the building to determine whether or not an interior braced wall line is needed. (Spaced no more than 35 ft. apart, or up to 50 ft., with conditions.) [Comm 21.25(8)(e)1. & 2.]
3. Grid Line # 1
 - First check to see if you can comply with the wall bracing provisions of Comm 21.25 (8) for 4 ft. wide panels or let-in bracing. This wall does not have the 4 ft. wide space available on either side of the garage door.
 - An option, as identified on the plan, would be to use the continuously sheathed method of Comm 21.29(9)(c), Fig. 21.25-K with 2' returns.
 - If the garage wall height is 9 ft., this design with the 3" nailing pattern and sheathing overlapping the header permits you to have sheathing on the sides of the garage door opening of 18" min. OK
 - The percent of braced wall panels provided shall be checked for conformance with Comm 21.25(9)(c)5.c., Table 21.25-H. The length required for this wall line would be $23' \times 0.16 = 3.68$ ft. OK.
 - Be reminded that the corners at the end of this braced wall line will have to be constructed in accordance with Fig 21.25-G.
 - Another option to consider is Comm 21.25(8)(c)2.c., Table 21.25-G. If the wall height of the garage is 9 ft., braced wall panels could be reduced from 48" to 42" in width. If 42" width is provided, then the continuously sheathed method with 3" nailing pattern and 2 foot returns would not be needed. This would still meet the percentage requirements of Tables 21.25-G and 21.25-H. [23 ft. \times $0.16 = 3.68$ ft. The effective length of 36 in. from Table 21.25-G \times 2 sides = 72" or 6 ft. $>$ 3.68 ft. OK]
4. Grid Line # 2 - Provide 4 ft. wide panels or let-in bracing within 12.5 feet of each end.
5. Grid Line # 3 - This grid line contains interior and exterior wall segments that are offset no more than 4 ft. from the braced wall line. Since this is considered one braced wall line, braced wall panels or let-in bracing must only be provided within 12.5 ft. of the ends and spaced no more than 25 ft. on center. As this is no more than 35 ft. from grid line #1 and Grid line #4 this satisfies the maximum 35 ft. braced wall line spacing requirements. Note: Grid line # 4 was used for this spacing determination instead of grid line #5 as it is that exterior wall that has the majority of the braced wall panels to resist the wind loads.

6. Grid Line # 4 - Provide 4 ft. wide panels or let-in bracing within 12.5 ft. of each end and a max. of 25 ft. on-center.

7. Grid Line # 5 - Provide 4 ft. wide panels or let-in bracing within 12.5 feet of each end. The plan shows 2 - 4 ft. wide panels. The code may be met by using just one panel in the center of the braced wall line as this would be within 12.5 ft. of each end. The single panel would also meet the percentage requirements of Table 21.25-H. [$15 \text{ ft.} \times 0.16 = 2.4 \text{ ft.} < 4 \text{ ft.}$ provided.]

8. Grid Line A

- Provide 4 ft. wide panels within 12.5 ft. of each end and a max. of 25 ft. on-center.
- Note: The plans show that let-in/diagonal bracing can be used in this braced wall line. After further review and consideration it has been determined that let-in bracing can not be used because this is a braced wall line that exceeds the 35 ft. braced wall line spacing requirement (grid lines A and D) resulting in a need for a check of an added amount of wall bracing required by Comm 21.25(8)(c)2.
- Determine percent wall bracing required. Since the distance between braced walls lines A and D is 46 ft. the required percentage would be $(46 \text{ ft.}/35 \text{ ft.} \times 0.16) \times 64 \text{ ft.}$ wall length = 13.5 ft. < 16 ft. provided. OK.

9. Grid Line B - Provide a 4 ft. wide panel within 12.5 ft. of each end.

10. Grid Line C - Provide 4 ft. wide panels within 12.5 ft. of each end. A single panel centered in the braced wall line would meet this requirement. Note, though, that a 2 ft. return may be required at the overhead garage door and the 4 ft. panel at the end would serve a dual purpose.

11. Grid Line D

- This grid line contains interior and exterior wall segments that are offset no more that 4 ft. from the braced wall line. Since this is considered one braced wall line, braced wall panels or let-in bracing must only be provided within 12.5 ft. of the ends and spaced no more than 25 ft. on center.
- Note: The plans show that let-in/diagonal bracing can be used in this braced wall line. After further review and consideration it has been determined that let-in bracing can not be used because this is a braced wall line that exceeds the 35 ft. braced wall line spacing requirement (grid lines A and D) resulting in a need for a check of an added amount of wall bracing required by Comm 21.25(8)(c)2.
- Determine percent wall bracing required. Since the distance between braced walls lines A and D is 46 ft. the required percentage would be $(46 \text{ ft.}/35 \text{ ft.} \times 0.16) \times 47 \text{ ft.}$ wall length = 9.9 ft. < 16 ft. provided. OK.





12. Grid Line E - Provide 4 ft. wide panels or let-in bracing within 12.5 feet of each end and a max. of 25 ft. on-center.

21.25(8)



Building #2
Two-Story

Front Elevation

-  Continuously- sheathed per s. Comm 21.25(9)(c)5.. Fig. 21.25-K. W/2
-  Four Feet of Wood Structural Panel Sheathing or Diagonal Bracing
-  Continuously- sheathed per s. Comm 21.25(9)(c) 2.&3.. W/2 foot
-  Four Feet of Gypsum Wallboard Applied to Both Sides of Wall or Diagonal

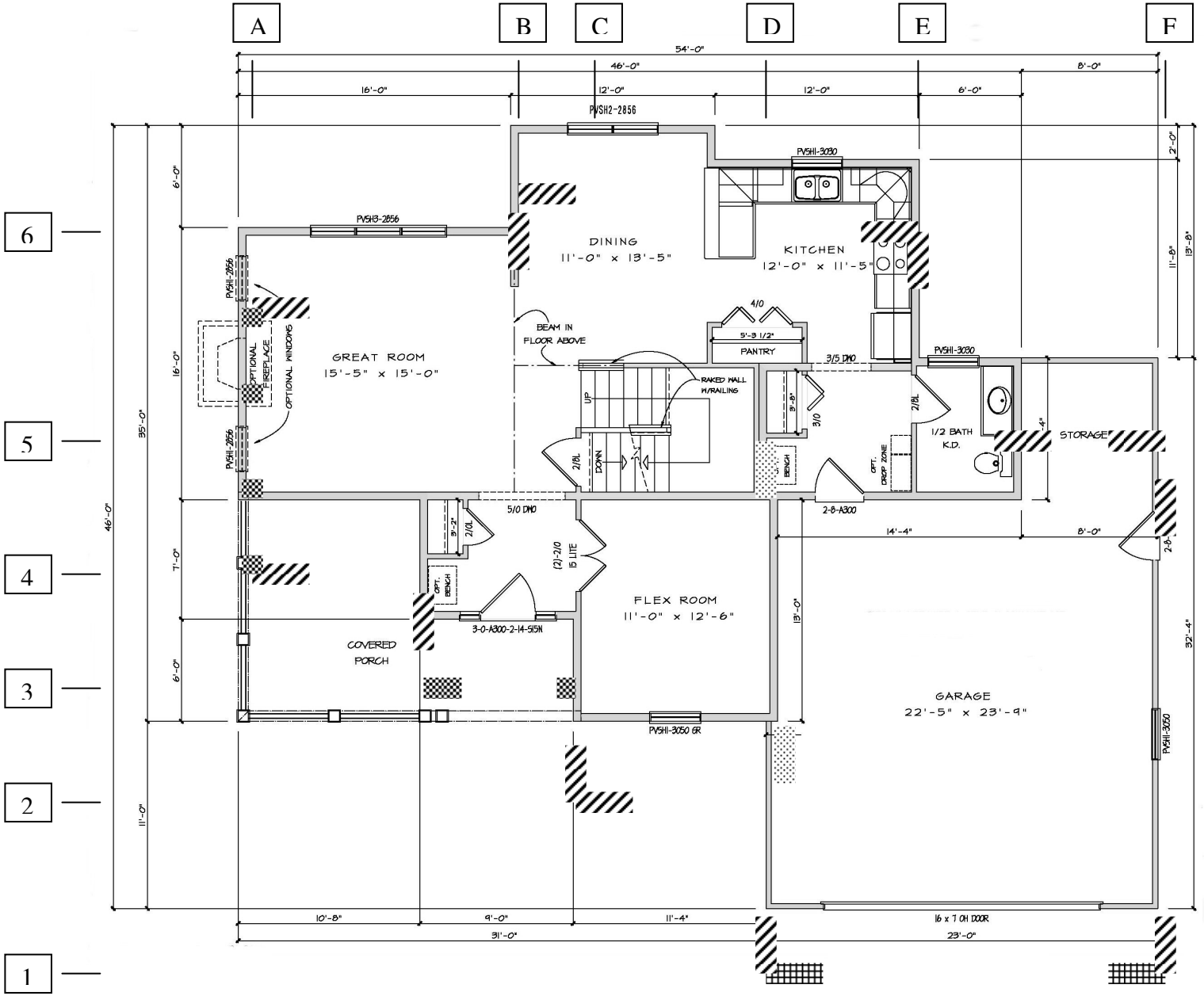

Building #2
Two-Story
First Floor

21.25(8)

Steps used to determine wall bracing for Bldg. # 2

[Note: The plans and selected bracing solutions were presented at the winter 2009 building inspector association sponsored UDC training sessions. Alternative wall bracing solutions have been provided in this training module.]

1. Find braced wall lines in exterior walls using north-south and east-west grid line pattern. Braced wall lines may include walls that are offset no more than 4 ft. [Comm 21.25(8)(e)]
2. Check the width of the building to determine whether or not an interior braced wall line is needed. (Spaced no more than 35 ft. apart or up to 50 ft. with conditions.) [Comm 21.25(8)(e)1. & 2.]

Steps used to determine wall bracing for Bldg. # 2, First Floor

3. Grid Line # 1

- First check to see if you can comply with the wall bracing provisions of Comm 21.25 (8) — 4 ft. wide panels or let-in bracing. This wall does not have the 4 ft. wide space available on either side of the garage door.
- An option, as identified on the plan, would be to use the continuously sheathed method of Comm 21.29(9)(c), Fig. 21.25-K with 2' returns.
 - If the garage wall height is 9 ft., this design with the 3" nailing pattern and sheathing overlapping the header permits you to have sheathing on the sides of the garage door opening of 18" min. OK
 - The percent of braced wall panels provided shall be checked for conformance with Comm 21.25(9)(c)5.c., Table 21.25-H. The length required for this wall line would be $23' \times 0.16 = 3.68$ ft. OK.
 - Be reminded that the corners at the end of this braced wall line will have to be constructed in accordance with Fig 21.25-G.
- Another option to consider is Comm 21.25(8)(c)2.c., Table 21.25-G. If the wall height of the garage is 9 ft., braced wall panels could be reduced from 48" to 42" in width. If 42" width is provided, then the continuously sheathed method with 3" nailing pattern and 2 foot returns would not be needed. This would still meet the percentage requirements of Tables 21.25-G and 21.25-H. [23 ft. \times $0.16 = 3.68$ ft. The effective length of 36 in. from Table 21.25-G \times 2 sides = 72" or 6 ft. $>$ 3.68 ft. OK]

4. Grid Line # 2 - Provide a 4 ft. wide panel or let-in bracing within 12.5 feet of each end.

5. Grid Line # 3.

- This wall does not have the 4 ft. wide space available on either side of the entrance door. The continuously sheathed method, as identified on the plan, will need to be used. In accordance with Table 21.25-J, the braced wall segments at the ends of this braced wall line will have to be at least 32 in.

wide and have a return at the ends of at least 2'. In addition the corners will have to be constructed in accordance with Fig. 21.25-G.

- An option, if the builder can not meet the 32" min. braced wall panel length requirement, would be to use the continuously sheathed method of Comm 21.29(9)(c), Fig. 21.25-K with 2' returns. The additional nailing and overlapping of sheathing over a header would permit a braced wall panel width of 16" in an 8 ft. high wall.

6. Grid Line # 4 - Provide a 4 ft. wide panel or let-in bracing within 12.5 feet of each end.

7. Grid Line # 5 - Provide 4 ft. wide panels or let-in bracing within 12.5 ft. of each end and a max. of 25 ft. on-center. The plan shows 2 - 4 ft. wide panels. The code may be met by using just one panel in the center of the braced wall line as this would be within 12.5 ft. of each end. The single panel would also meet the percentage requirements of - H. [14 ft. X 0.16 = 2.24 ft. < 4 ft. provided.]

8. Grid Line # 6

- This grid line contains exterior wall segments that are offset no more than 4 ft. from the braced wall line. Since this is considered one braced wall line, braced wall panels or let-in bracing must only be provided within 12.5 ft. of the ends and spaced no more than 25 ft. on center.
- Determine percent wall bracing required per Table 21.25-H.: 40 ft. wall length X 0.16 = 6.4 ft. < 12 ft. provided. OK.

9. Grid Line A

- This wall does not have the 4 ft. wide space available between the fireplace and the windows, if all were provided in this braced wall line. The continuously sheathed method was identified as an option on the plan. In accordance with Table 21.25-J, this would mean that the braced wall segments at the ends of this braced wall line will have to be at least 24 in. wide if the wall is 8 ft. in height and the windows do not take up more than 67% of the wall height.
- If this width can not be met, the fireplace will have to go if the windows are provided and, if the fireplace is provided, the windows must go. Also, if the fireplace or windows are not provided there may be enough space in the braced wall line to get a 4 ft. braced wall panel in and thus eliminating the 2 ft. returns, and specially constructed corners per Fig. 21.25-G.
- Another option may be use Comm 21.25(9)(c)5., Fig. 21.25-K with returns.

10. Grid Line B - Provide a 4 ft. wide panel within 12.5 ft. of each end.

11. Grid Line C - Provide 4 ft. wide panels within 12.5 ft. of each end. A single panel centered in the braced wall line would meet this requirement. Note that, if a 2 ft. return is required at the overhead garage door, the 4 ft. panel at the end would serve a dual purpose.

21.25(8)

12. Grid Line D

- This grid line contains interior and exterior wall segments that are offset no more than 4 ft. from the braced wall line. Since this is considered one braced wall line, braced wall panels or let-in bracing must only be provided within 12.5 ft. of the ends and spaced no more than 25 ft. on center.
- Note: The plans show that let-in/diagonal bracing can be used in this braced wall line. After further review and consideration it has been determined that let-in bracing can not be used because this is a braced wall line that exceeds the 35 ft. braced wall line spacing requirement (grid lines A and D) resulting in a need for a check of an added amount of wall bracing required by Comm 21.25(8)(c)2.
- Determine percent wall bracing required. Since the distance between braced walls lines A and D is 46 ft. the required percentage would be $(46 \text{ ft.} / 35 \text{ ft.} \times 0.16) \times 47 \text{ ft. wall length} = 9.9 \text{ ft.} < 16 \text{ ft. provided. OK.}$

13. Grid Line E - Provide 4 ft. wide panels or let-in bracing within 12.5 feet of each end and a max. of 25 ft. on-center.

Four Feet of Wood Structural Panel Sheathing or Diagonal

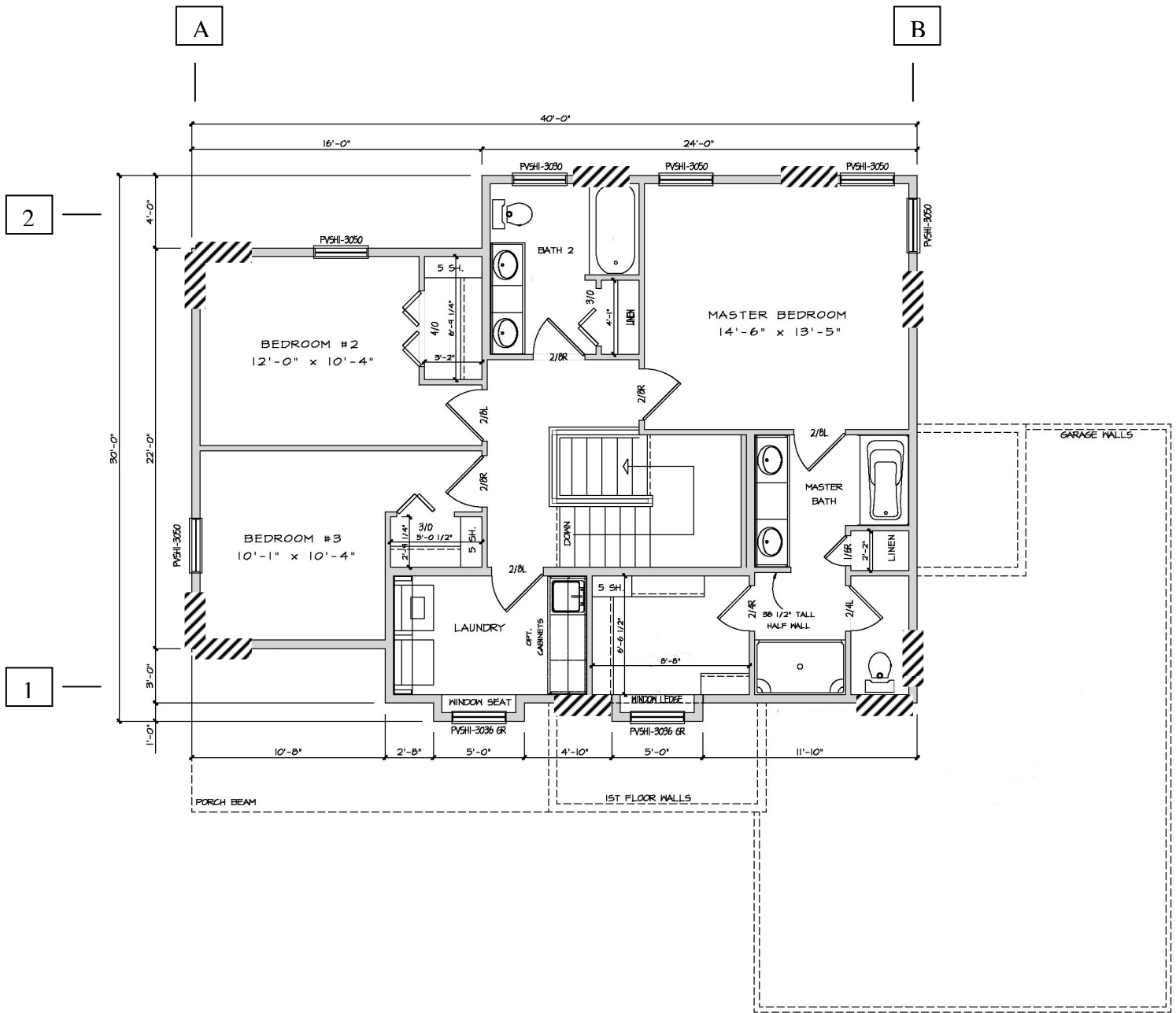

Building #2
Two-Story

Second Floor

Steps used to determine wall bracing for Bldg. # 2, Second Floor

1. Grid Line # 1

- This grid line contains exterior wall segments that are offset no more than 4 ft. from the braced wall line. Since this is considered one braced wall line, braced wall panels or let-in bracing must only be provided within 12.5 ft. of the ends and spaced no more than 25 ft. on center.
- Determine percent wall bracing required per Table 21.25-H.: 40 ft. wall length $\times 0.16 = 6.4$ ft. < 12 ft. provided. OK.

2. Grid Line # 2

- This grid line contains exterior wall segments that are offset no more than 4 ft. from the braced wall line. Since this is considered one braced wall line, braced wall panels or let-in bracing must only be provided within 12.5 ft. of the ends and spaced no more than 25 ft. on center.
- Determine percent wall bracing required per Table 21.25-H.: 40 ft. wall length $\times 0.16 = 6.4$ ft. < 12 ft. provided. OK.

3. Grid Line A

- Provide 4 ft. wide panels within 12.5 feet of each end and a max. of 25 ft. on-center.
- Note: The plans show that let-in/diagonal bracing can be used in this braced wall line. After further review and consideration it has been determined that let-in bracing can not be used because this is a braced wall line that exceeds the 35 ft. braced wall line spacing requirement (grid lines A and D) resulting in a need for a check of an added amount of wall bracing required by Comm 21.25(8)(c)2.
- Determine percent wall bracing required. Since the distance between braced walls lines A and D is 40 ft. the required percentage would be $(40 \text{ ft.}/35 \text{ ft.} \times 0.16) \times 22 \text{ ft. wall length} = 4.0$ ft. < 8 ft. provided. OK.

4. Grid Line B

- Provide 4 ft. wide panels within 12.5 feet of each end and a max. of 25 ft. on-center.
- Note: The plans show that let-in/diagonal bracing can be used in this braced wall line. After further review and consideration it has been determined that let-in bracing can not be used because this is a braced wall line that exceeds the 35 ft. braced wall line spacing requirement (grid lines A and D) resulting in a need for a check of an added amount of wall bracing required by Comm 21.25(8)(c)2.
- Determine percent wall bracing required. Since the distance between braced walls lines A and D is 40 ft. the required percentage would be $(40 \text{ ft.}/35 \text{ ft.} \times 0.16) \times 30 \text{ ft. wall length} = 5.5$ ft. < 8 ft. provided. OK.

Subchapter VIII — Roof and Ceilings

21.27(1)(c) Sloped Roof Snow Loads

This section allows reduction of snow loads on roofs sloped more than 30 degrees. This means a reduction may be taken on roofs with greater than a 7:12 slope. This reduced design snow load may be transmitted down through the structure including any headers or beams. (See table below for examples.)

However, it must be remembered that s. Comm 20.02 also requires a 20 PSF wind load acting on the vertical roof projection.

Reduced Snow Load for High Slope Roofs = $C_s \times \text{Design Snow Load}$

$$C_s = [1 - (a - 30)]/40$$

$$a = \text{angle in degrees}$$

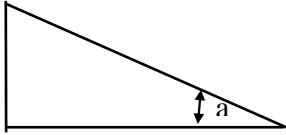

	Slope	a	Zone 1 PSF	Zone 2 PSF
	7/12	30	40	30
	10/12	40	30	22.5
	12/12	45	25	18.8
	14/12	50	20	15

Rise/Run = Slope = $\tan a$
Arctan(slope) = a

21.27(2) Resistance to Horizontal Wall Thrust from Rafters

Sloping roof rafters will push their supporting walls outward unless this force is properly resisted. Collar ties, which are required in the upper one-third of the rafter, provide some fixity of in the joining of the upper rafter ends, but do not provide much resistance to outward wall thrust. Typically the horizontal wall thrust needs to be resisted by wall ties or ceiling joists or by a ridge beam sized to carry half of the rafter loads.

21.28(6) Reroofing

Question: Can re-roofing be done without removing the existing layers of roofing?

Answer: The subject of the number of layers of roofing materials that can be placed now onto an existing roof system is now addressed in the dwelling code specifically and limited to two [one new layer on top of one existing layer]. However, the design loads of the roof rafter or trusses should not be exceeded. The span tables in the UDC assume dead loads that will typically allow a total of two lightweight roof layers. Additionally, the installation of the roof covering materials would have to be in accordance with the installation requirements.

Subchapter IX —Fireplace Requirements

21.29 Masonry Fireplaces

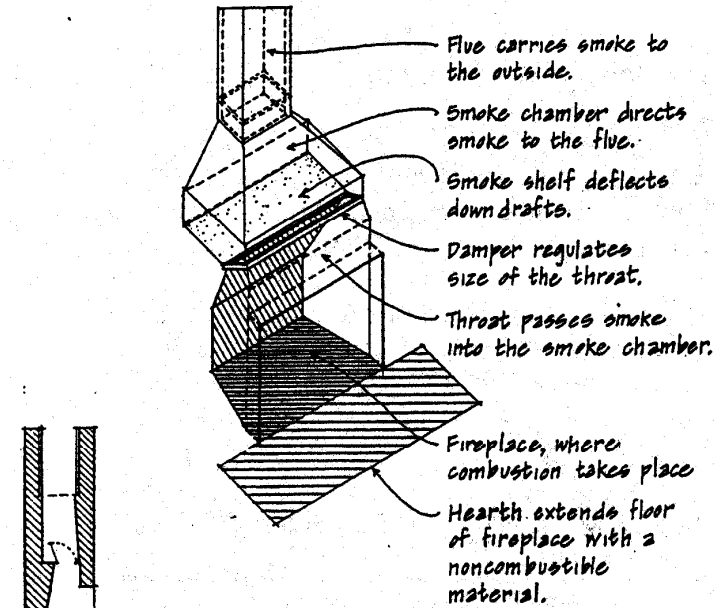

A fireplace should be designed and constructed to:

- Sustain the combustion of the fuel
- Draw properly to carry smoke and other combustible by-products to the outside
- Radiate the maximum amount of heat comfortably into the room
- Ensure proper distances from combustible materials.

Thus the dimensions and proportions of a fireplace and its flue, and the arrangement of its components, are subject to the laws of nature and the requirements of the building and mechanical codes.

The table below provides typical dimensions for three types of fireplaces.

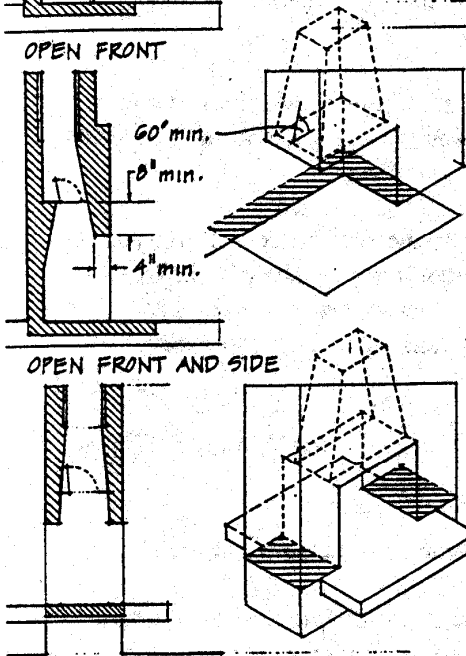

TYPICAL FIREPLACE DIMENSIONS (inches)

Width (A)	Height (B)	Depth (C)	Back width (D)	Vertical back (E)	Smoke chamber (F)	Damper width (G)	Flue size
OPEN FRONT							
24	24	16	11	14	19	32	8 x 12
28	24	16	15	14	21	36	8 x 12
32	29	16	19	14	24	40	12 x 12
36	29	16	23	14	27	44	12 x 12
42	32	16	29	14	32	50	16 x 16
48	32	18	33	14	37	56	16 x 16
54	37	20	37	16	45	60	16 x 16
60	40	22	42	16	45	72	16 x 20
72	40	22	54	16	56	84	20 x 20
OPEN FRONT AND SIDE							
28	24	16	/				12 x 12
32	28	18					12 x 16
36	30	20					12 x 16
48	32	22					16 x 16
OPEN FRONT AND BACK							
28	24	16	/				12 x 12
32	28	16					12 x 16
36	30	17					12 x 16
48	32	19					16 x 16

OPEN FRONT AND BACK

Multifaced fireplaces are especially susceptible to drafts in a room; avoid placing their openings opposite an exterior door.

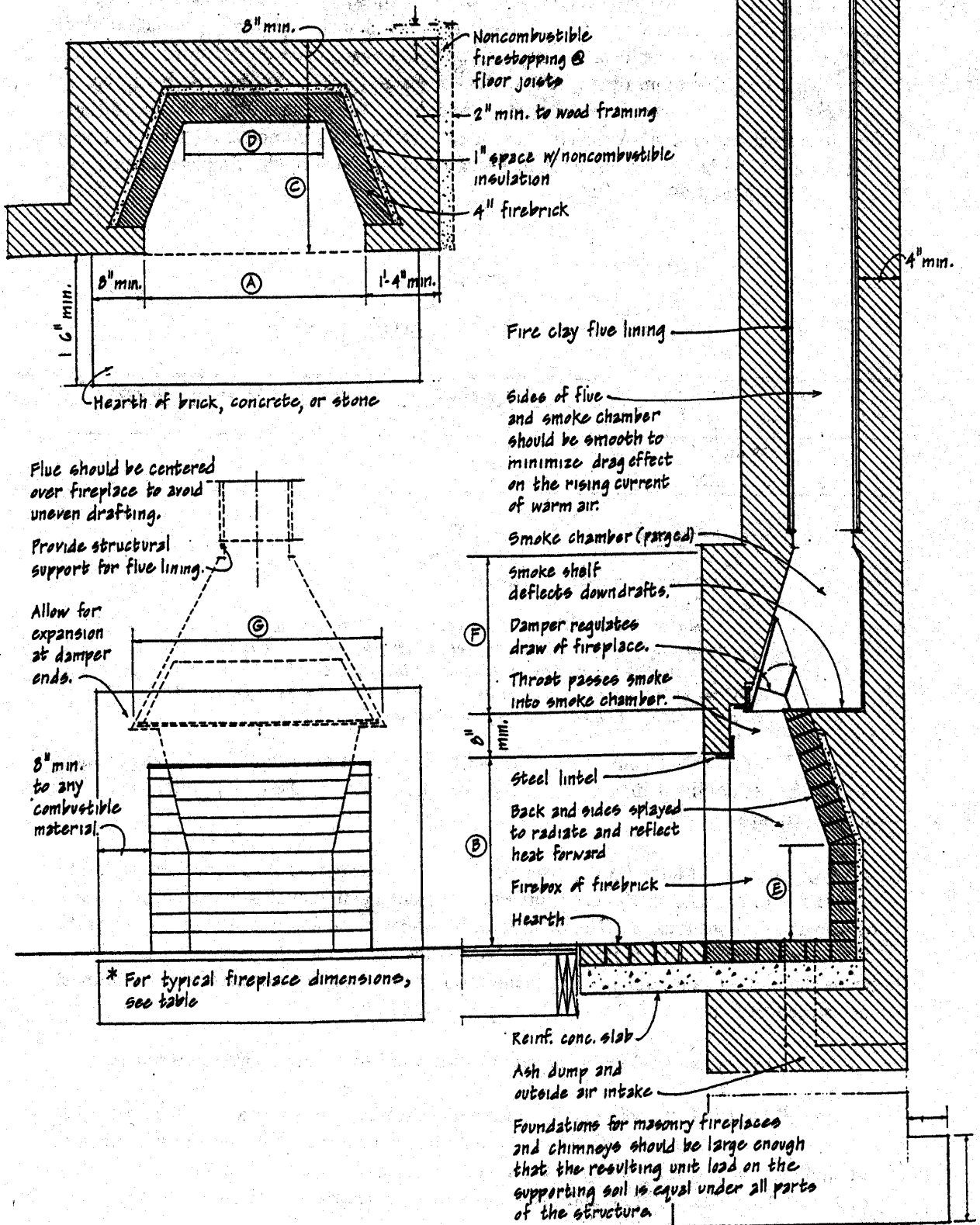

21.29(6) Hearth Extension

Question: How is the hearth extension measured?

Answer: The hearth or hearth extension is measured from the face of the fireplace opening and not from the front of the firebox, spark screen, or glass doors. The face of the fireplace includes any trim materials provided on the front of the fireplace. Earlier editions of the UDC permitted measurement from the firebox, but as of the 1989 Edition, the measurement is to be taken from the face of the fireplace opening.

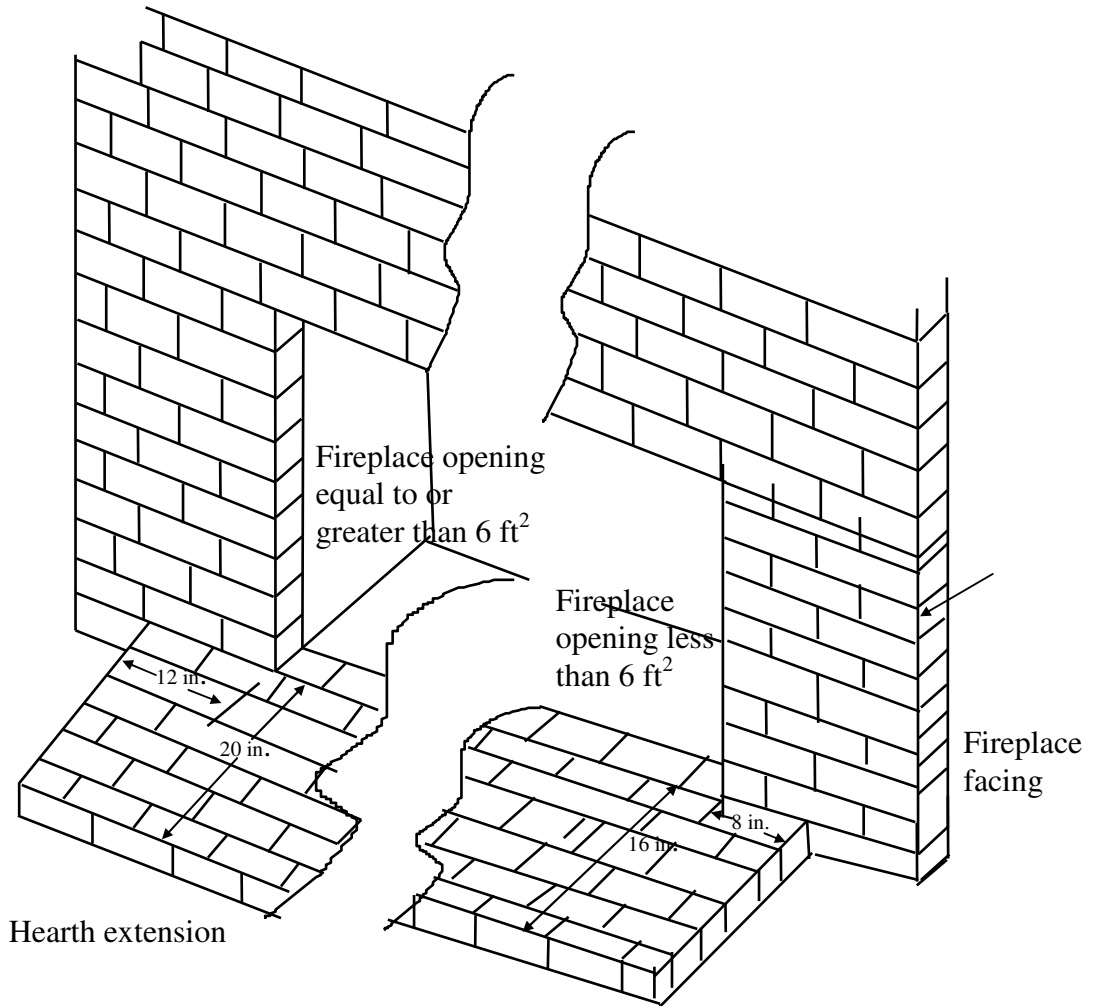

Fireplace hearth extension requirements

21.29(12) Framing Around Fireplaces

Question: This section refers to 21.30(9) which requires 2-inch clearances from fireplace masonry to combustibles. In some cases, the block and brick may cover an entire wall. In such a case, is it necessary to maintain the 2-inch clearance from the entire wall?

Answer: Because of the expected heat dissipation in such an installation, the department will accept the ends of the beams and headers to be placed without a 2-inch clearance if at least 12 inches of solid masonry is also provided between the member and the firebox or chimney flue. If the wood structural member is supported in the masonry, it must be fire cut or a self-releasing device must be used as required by s. Comm 21.26(9)(c).

Note the requirement for clearances to a fireplace applies only to framing. Other combustible elements such as mantles, trim, and flooring would need to comply with the s. Comm 21.29(11), as well as the hearth requirements of s. Comm 21.29(6).

21.30(7) Flue Liners

Question: If a stainless steel flue liner is used, what gauge stainless steel may be used to line a masonry chimney?

Answer: Stainless steel of 22 gauge or thicker is acceptable.

21.30(9) Fireblocking of Chimneys

Question: The Uniform Dwelling Code requires 2 inches of clearance between combustible headers, beams, rafters, joists and studs and the outside face of a interior chimney (1 inch for an exterior chimney). Does subs. Comm 21.085(1) on fire separation also apply where this rule states "holes around ducts and pipes shall also be fireblocked"?

Answer: Yes. It is the intent for Comm 21.085(1) and 21.30(9)(a) to apply to the 2-inch or 1-inch clearance between the chimney and the structural members. Noncombustible fire blocking material must be used. In addition, insulation is not acceptable for fire blocking metallic chimneys or vents per Comm 21.30(9)(b)&(c) as this would cause "hot spots" to occur and most likely harm them and/or void the manufacturer's testing.

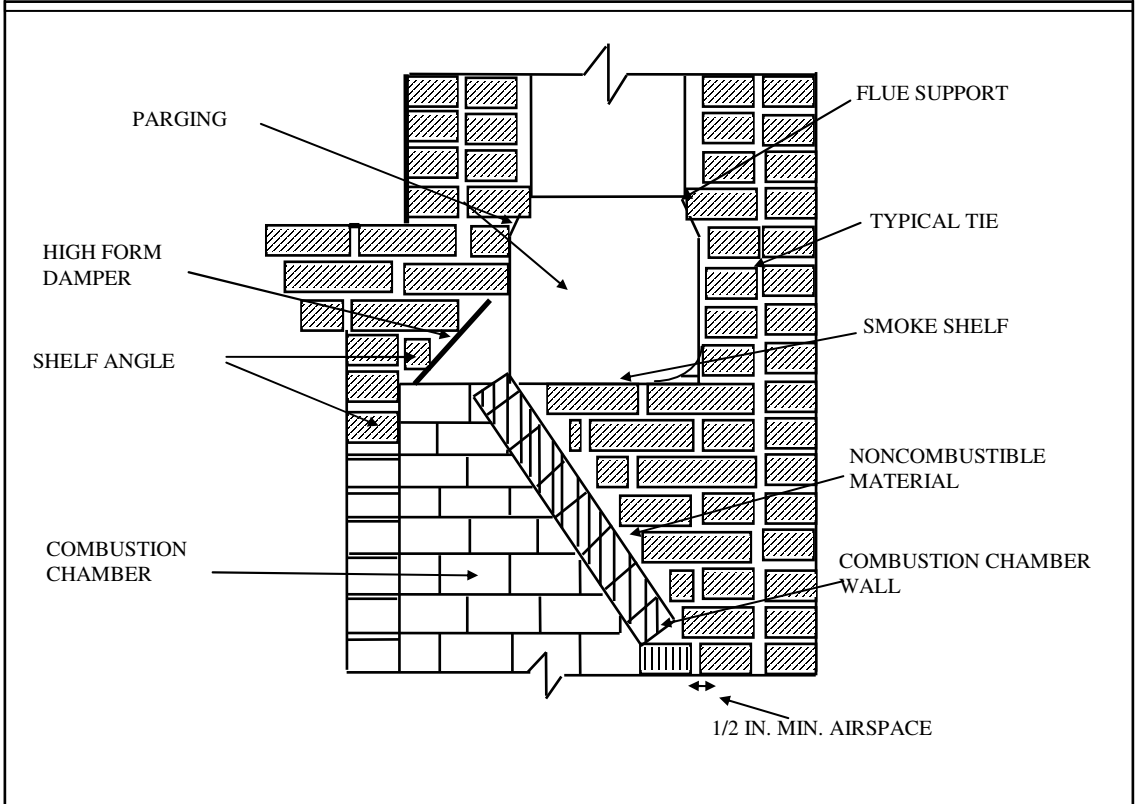
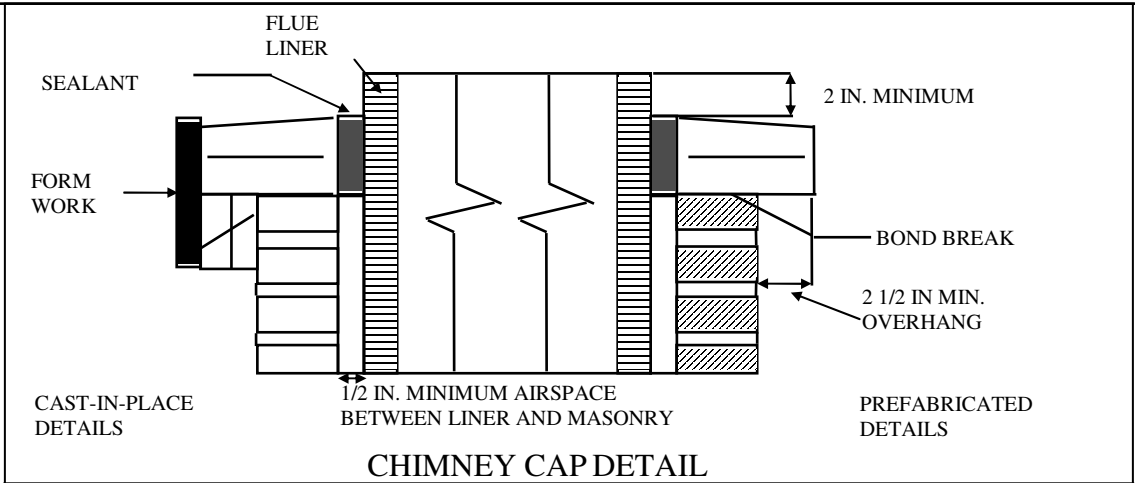
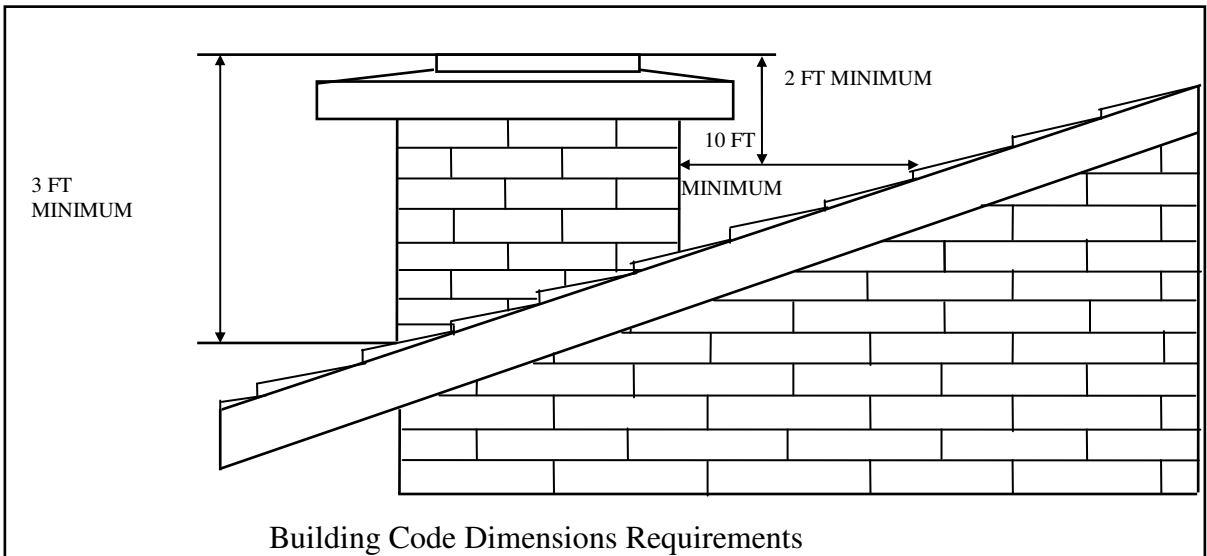

21.32 Factory-Built Fireplaces

The department conducted an investigation regarding factory-built fireplace installations. As a result of the investigation, it was felt special consideration should be given to two important installation requirements that are especially important to proper operation of such fireplaces.

Per s. Comm 21.32, factory-built fireplaces and their specified chimneys shall be tested and listed by a nationally recognized testing laboratory. Furthermore, the fireplace assembly and chimney shall be erected and maintained in accordance with the conditions of the listing. Currently acceptable testing and listing laboratories for this and other purposes are listed below. Not all will test all classes of appliances.

- Underwriter's Laboratories (UL)
- Electrical Testing Labs of New York (ETL-NY)
- Energy Testing Labs of Maine (ETL-MAINE)
- Canadian Standards Association (CSA)
- Product Fabrication Service (PFS)
- Warnock Hersey

Specific emphasis should be placed on inspection of the construction gap between the front of the fireplace unit and the finish material or fascia. Most, if not all, manufacturers require the gap be filled with noncombustible caulk or equivalent. The fear, although not specifically verified by our investigation, is that hot gases or sparks can migrate out of the fire box through such an opening and eventually cause ignition of the unprotected combustibles behind the fascia. Improper drafting could increase the likelihood of such an occurrence.

Typically the crack between the fireplace and hearth must also be properly sealed against entry of sparks and coals if there is combustible flooring below.

The use of any add-on items should be closely checked as to whether they are listed for that particular fireplace. Be especially suspicious of retrofitted stoves or fireplace inserts which can cause severe problems if the fireplace was not designed for them.

Also, fireplace doors should be checked to verify that they are of a type made by the fireplace manufacturer and approved for installation on that model. Oversize doors could restrict combustion air supply, block air circulation vents or slots that cool the unit or even deflect heat or hot gases laterally into the construction gap between the front of the unit and the surrounding fascia as described above.

In conclusion, all manufacturer's installation requirements should be followed. An inspector is entitled to request a copy of manufacturer's installation instructions, per s. Comm 20.09(4)(b), in order to conduct proper inspections.

Question: Many pre-manufactured fireplace installation instructions require a noncombustible insulating material be placed between the hearth extension

21.32

finish material and the combustible floor. Is this noncombustible insulating board required by the UDC?

Answer: Indirectly, yes. Section Comm 21.32(1) requires the entire fireplace installation be installed per the manufacturer's listing. The hearth extension design is part of the listing. The insulating board specifications vary between fireplace manufacturers. For example, some "Preway" Models requires either of two of its products, "Preway" HE 36-1 or HE 3624. An alternative material should be equal to 3/4-inch thick noncombustible insulating material with a thermal conductivity of $k = 0.55 \text{ (Btu)(in)/(hr)(sqft)(}^\circ\text{F)}$. As an alternative to k-value, a 3/4-inch noncombustible material with a thermal conductance $C = .73$ or thermal resistance $R = 1.36$ is acceptable. Besides the Preway products mentioned, other trade name products such as "Celotex CV 230", "Micore" and "Spec 300" boards may also be acceptable (check k-values).

21.32 Gas Fireplaces

Question: Are gas-only fireplaces required to have a hearth extension per the UDC?

Answer: No. Gas-only fireplaces are covered by s. Comm 23.04 as a gas appliance and need to be installed per their listing, which typically may not require a hearth extension.

21.32 Factory-Built Fireplace Chimneys

Question: Does the requirement of s. 23.045(3)(a)1., that factory-built chimneys be tested to 2,100°F ("high-temperature" rated) if connected to a solid-fuel appliance, apply to a factory-built fireplace?

Answer: No. Section 23.045 applies to solid-fuel appliances other than those covered by other sections of the code such as masonry and factory-built fireplaces (ss. Comm 21.29 through 21.32). The proper chimney for a factory-built fireplace is the one it was tested and listed with and is normally shipped with the unit. It is possible that such listed fireplace assemblies will have a lower temperature chimney.

Subchapter X — Construction in Floodplains

This is the only place in the UDC that licensed architect or professional engineer can be required by code language to verify code is met [all other code compliance calculations may be accepted from non-licensed persons, but for this it must be from licensed persons].

Subchapter XI — Installation of Manufactured Homes

21.40 Manufactured Homes

Since April 1, 2007 manufactured homes [formerly know as mobile homes or HUD homes] are required by UDC to meet certain installation standards. Please see information on the Safety & Buildings website under the Manufactured Home program for more complete information on the regulation and installation of these homes. Links from that program page currently include minimum acceptable foundation design, with limitations and also include a draft version of the federal installation standards from HUD.

<http://www.commerce.state.wi.us/SB/SB-ManufacturedMobileHomesProgram.html>

The manufacture date of the home is key to the installation standards that it must follow, as well as the edition of the electrical code and other codes governing the interior of that home. However any site-constructed additions or foundations to such homes are covered by the current UDC, as noted in Comm 20.04(5)(b) that would require the new home placed on an existing foundation to have that foundation need to be UDC inspected and brought up to current UDC code minimums.

For older manufactured homes being installed on a new site and foundation, Comm 21.40(2) gives two options. First they can install it per the requirements in effect at the time the manufactured home was produced - this is per the manufacturer's installation instructions that is similar to the post April 1, 2007 homes method. The second option is to install on piers per the 17 minimum requirements of Comm 21.40(2)(b).

Manufactured Home Foundation Requirements

Manufactured Home Production Date	Home on Piers (supported by individual footings or a slab)	Home on Basement or Crawlspace	Additions to Home
Pre June 1, 1980	s. Comm 21.04(2) <ul style="list-style-type: none"> • No anchorage required • No footings below frost depth or frost protection required 	Per any municipal requirements relating to basements or crawlspaces for a pre-June 1, 1980 dwelling	Per any municipal requirements relating to additions to a pre-June 1, 1980 dwelling
June 1, 1980 through March 31, 2007	s. Comm 21.04(2) <ul style="list-style-type: none"> • No anchorage required • No footings below frost depth or frost protection required 	Per UDC general requirements: <ul style="list-style-type: none"> • Anchorage of home to basement or crawlspace required • Footings of basement or crawlspace below frost depth or frost protected 	Per UDC general requirements: <ul style="list-style-type: none"> • Anchorage of addition to its foundation required • Footings of addition below frost depth or frost protected (see s. Comm 21.15(1)(e) regarding "floating" structure if home is not supported on frost-protected
On or after April 1, 2007	s. Comm 21.04(1) <ul style="list-style-type: none"> • Anchorage required • Footings below frost depth or protected 	Per UDC general requirements: <ul style="list-style-type: none"> • Anchorage required • Footings below frost depth or frost protected 	Per UDC general requirements: <ul style="list-style-type: none"> • Anchorage required • Footings below frost depth or frost protected